

**NOTICE OF REGULAR COUNCIL MEETING  
CUMMING CITY COUNCIL**

**August 10, 2020 – 7:00 p.m.**

**Cumming City Hall, 649 N 44<sup>th</sup> St., Cumming Iowa\***

This is a tentative agenda only, which is subject to change. The final City Council agenda will be posted at least 24 hours prior to commencement of the meeting.

- I. **ROLL CALL**
- II. **APPROVAL OF AGENDA** as presented and/or amended
- III. **PUBLIC COMMENT**
- IV. **BOARDS AND COMMISSIONS REPORTS**
  - A. Park and Recreation
  - B. Planning and Zoning
- V. **CONSENT ITEMS**
  - A. 7/13/20 Council Meeting Minutes
  - B. 7/28/20 Planning and Zoning Minutes
  - C. July IPERS Wage & Contribution Report
  - D. July 2020 Fund Balance Report
  - E. July 2020 Claims Paid & Summary of Receipts
  - F. Claims to Be Approved
  - G. July Deposit Detail
  - H. July Building Permit Log
  - I. Transient Merchant Sales Registration – DamonLayne Woodworking
  - J. Transient Merchant Sales Registration – Iowa Family Chiropractic
  - K. Appoint Jordyn Hill to the Planning & Zoning Board for a five year term
- VI. **ACTION/DISCUSSION ITEMS**
  - A. **Presentation** – Great Western Crossing Park – Revision, Tom Henderson
  - B. **Presentation** – Hometown Pride Update and Fundraising, Pat Whalen
  - C. **Resolution 2020-50** An Authorization for Payment of Hometown Pride Vendor Obligations not to exceed \$1,500.00.
  - D. **Resolution 2020-51** Licensing Agreement with Ben Schuh, Plum Forward
  - E. **Public Hearing:** Amending the Code of Ordinances, City of Cumming, Iowa, by Amending Chapter 90, Water Service System
  - F. **First Reading of Ordinance 2020-05** Amending the Code of Ordinances, City of Cumming, IA by Amending Provisions pertaining to Chapter 90 Water Service System with option to waive the second and third readings and motion for clerk to post
  - G. **Second Reading of Ordinance 2020-02** An Ordinance Adopting the Code of Ordinances of the City of Cumming, Iowa with option to waive the third reading and motion for clerk to post
  - H. **Second Reading of Ordinance 2020-03** Amending the Code of Ordinances, City of Cumming, IA by Amending Provisions pertaining to Chapter 55 Animal Protection and Control with option to waive the third reading and motion for clerk to post
  - I. **Second Reading of Ordinance 2020-04** Amending the Code of Ordinances, City of Cumming, IA by Amending Provisions pertaining to Chapter 69.09 Truck Parking Limited with option to waive the third reading and motion for clerk to post

# NOTICE OF REGULAR COUNCIL MEETING

## CUMMING CITY COUNCIL

August 10, 2020 – 7:00 p.m.

Cumming City Hall, 649 N 44<sup>th</sup> St., Cumming Iowa\*

This is a tentative agenda only, which is subject to change. The final City Council agenda will be posted at least 24 hours prior to commencement of the meeting.

- J. **Resolution 2020-49** Set a Date for Public Hearing to Rezone Certain Property within the City Limits of Cumming from A-1 Agriculture District to C-1 Highway Commercial District and Amend the Official Zoning Map of the City of Cumming, Iowa
  - K. **Resolution 2020-52** Setting a Date for Public Hearing on Urban Renewal Plan Amendment
  - L. **Resolution 2020-53** Approval Plat of Survey
  - M. City Administrator Discussion
  - N. **Resolution 2020-54** Resolution of the City of Cumming Relating to Employment of the City Administrator Applicable to Employees Not Within the Civil Service
  - O. **Resolution 2020-55** Approving Employment Contract Agreement
  - P. **Resolution 2020-56** Approving City Administrator Compensation Package
  - Q. **Resolution 2020-57** Set a Date for a Public Hearing to Amend the Code of Ordinances, City of Cumming, Iowa by Amending Chapter 122 Peddlers, Solicitors and Transient Merchants
  - R. 28E Agreement with Norwalk, Fire Protection and Emergency Services
  - S. Emergency Siren/Alert System
  - T. Internet Service
  - U. No Parking, South Side
  - V. Mosquito Abatement Service Agreement
  - W. City Park Mulch/Repair Bids
- VII. **REPORTS:**
- A. Mayor
  - B. Council
  - C. Attorney
  - D. Clerk
- VIII. **PUBLIC COMMENT**
- IX. **UPCOMING CITY COUNCIL MEETING:** Regular Meeting: September 14, 7:00 p.m. at City Hall
- X. **ADJOURN**

\*This meeting will be held electronically through the Zoom App. If you would like to participate or view this meeting please download the app and choose "Join Meeting" up to 10 minutes prior. The **meeting ID is: 879 8100 5255. Password: 275696**. If you would like to join by telephone please call: 312-626-6799 and enter the Meeting ID and Password when prompted.

Please keep your microphone muted unless you are called upon to speak during public comment. The standard rules of order apply during this meeting.

If have any questions about the operation of this app or how to join please contact City Hall at 515-981-9214.

**OFFICIAL PUBLICATION  
CITY OF CUMMING  
Regular Council Meeting 7/13/2020  
To be Approved at 8/10/20**

The Regular City Council Meeting of the City of Cumming was held via Zoom on Monday, July 13, 2020. The Meeting was called to order at 7:00 P.M. by Mayor Tom Becker. Present at Roll Call: Thomas Cackler, Brent Highfill, Charlie Ochanpaugh, Kathie Hungerford, and Dino Goode. The agenda was amended to reflect corrections to 6/8/20 Minutes and the removal of item 'I' of the Consent Items. Motion by Ochanpaugh, seconded by Goode to approve the agenda as amended. Approved 5-0.

**Park & Recreation:** John McPartland gave an overview of the Park and Recreation Board's thoughts on the new park as proposed by Diligent.

**Planning & Zoning:** Ethan Roos, acting P&Z chair, gave an update on the P&Z progress and upcoming meeting.

**Hometown Pride:** Design update given; fundraising brochure presented.

**Home Show Expo 2021:** Initial meeting held. Next meeting is scheduled for July 20<sup>th</sup>.

**Consent Items:**

Consent items "I and T" were removed. Consent item J was approved pending the box left open is marked as 'no' by the applicant. Motion made by Goode, seconded by Cackler, to approve the Consent items as amended: 6/8/20 Council Meeting Minutes, 6/23/20 Planning and Zoning Minutes, June 2020 IPERS Wage & Contribution Report, June 2020 Fund Balance Report, 6/21/20, 6/30/20 & 7/5/20 Calculation & Verification Journals, 6/11/20, 6/22/20, 6/30/20 & 7/9/20 Accts Payable Claims Reports, June Revenue Log, June Building Permit Log, Cumming Tap Cigarette License Renewal (pending notation above), Iowa Distillery Liquor License Renewal, the following Transient Merchant Sales: Clanton Creek Oils and Herbs, LLC, Charlotte's Kitchen, Corabelle Confections, Thirty-one Gifts, Loomies Rugs, LLC, TenX Mobile Adventures, Boy Scouts of America – Aidan Ritchie, Dust Control – Jericho Services Approved 5-0.

**Expenditures:**

ANGIE RITCHIE	FY20 4TH QTR MILEAGE/ZOOM	\$ 134.20
PLUM FORWARD CORP	1@2 PYMTS WATER TOWER ART	\$ 7,860.00
CARDMEMBER SERVICE	SPRINT	\$ 16.90
CENTURY LINK	PHONE & INTERNET	\$ 241.33
COMBINED SYSTEMS TECH	ANTIVIRUS	\$ 7.49
GOVOFFICE LLC	REMAINING BAL EMAIL/WEB	\$ 131.24
ICAP	LIABILITY INSURANCE PREM	\$ 3,960.77
IOWA LEAGUE OF CITIES	MEMBER DUES 7/1/20-6/30/21	\$ 384.00
IPERS	IPERS	\$ 492.13
IRS	FED/FICA TAXES	\$ 650.55
KATHIE HUNGERFORD	FY20 4TH QTR MILEAGE	\$ 11.04
KIRK FORD	PARK MAINT X7 5/2-6/13	\$ 735.00
LARRY GOODE JR	2 WRA MEETINGS AND MILES 19	\$ 73.62
MIDAMERICAN ENERGY	CITY HALL/STREET LIGHTS	\$ 734.60
MSA PROFESSIONAL SERVICES	PROFESSIONAL SERVICES	\$ 2,256.15
N/WARREN TWN & CTRY NEWS	JUNE 25TH PUBLICATIONS	\$ 175.59
NORWALK LIONS CLUB	FIREWORKS DONATION 2020	\$ 300.00
OFFICE DEPOT	OFFICE SUPPLIES	\$ 65.27
PRO-IMAGE SIGN & LIGHTING	HOMETOWN PRIDE BANNERS	\$ 76.00
STERNQUIST	ORILLA ROAD REPAIR	\$ 23,205.00
TOM BECKER	1ST & 2ND QTR MILEAGE	\$ 130.19
US BANK	COPIER LEASE	\$ 237.28

VEENSTRA & KIMM INC	PHASE 3 SEWER EXT MAY-JUNE	\$ 22,156.66
WARREN COUNTY OIL	152.6 G PROPANE CITY HALL	\$ 157.21
WASTE CONNECTIONS INC	GARAGE & RECYCLING	\$ 2,251.64
IOWA DEPT NAT RESOURCE	PHASE 3 SEWER EXT PERMIT	\$ 100.00
IOWA DEPT NAT RESOURCE	AN WATER SUPPLY FEE FY21	\$ 40.09
CITY OF DES MOINES	WRA PAYMENT	\$ 6,650.00
<b>Accounts Payable Total</b>		<b>\$ 73,233.95</b>
Total Paid On: 6/22/20	DEPUTY CLERK	\$ 1,175.59
Total Paid On: 6/30/20	COUNCIL/MAYOR QTR	\$ 1,278.89
Total Paid On: 7/09/20	DEPUTY CLERK	\$ 1,225.00
<b>Total Payroll Paid</b>		<b>\$ 3,679.48</b>
***** REPORT TOTAL *****		<b>\$ 76,913.43</b>
GENERAL		\$ 70,123.34
WATER		\$ 40.09
SEWER		\$ 6,750.00

#### Action Items

- A. Mayor Tom Becker opened the **Public Hearing** on Adoption of the Proposed Code of Ordinances of the City of Cumming, Iowa at 7:02 p.m. Motion by Hungerford, seconded by Cackler to close the public hearing at 7:47 p.m. No public or written comments were made. Approved 5-0.
- B. Motion by Cackler, seconded by Ochanpaugh to approve the first reading of **Ordinance 2020-02** An Ordinance Adopting the Code of Ordinances of the City of Cumming, Iowa. Approved 5-0.
- C. Mayor Tom Becker opened the **Public Hearing** on the Proposal to Enter into a General Obligation Sewer Improvement Loan Agreement at 7:02 p.m. Motion by Cackler, seconded by Highfill to close the Public Hearing at 7:50 p.m. No public or written comments were made. Approved 5-0.
- D. Motion by Ochanpaugh, seconded by Cackler to approve **Resolution 2020-41** Resolution Taking Additional Action to Enter into a Loan Agreement and Awarding the Sale of a General Obligation Sewer Improvement Note. Approved 5-0
- E. Mayor Tom Becker opened the **Public Hearing** on Ordering Construction of Certain Public Improvements and Approving Preliminary Plans at 7:02 p.m. Motion by Hungerford, seconded by Cackler to close the public hearing at 7:52 p.m. No public or written comments were made. Approved 5-0.
- F. Motion by Goode, seconded by Highfill to approve **Resolution 2020-42** Approving and Confirming Plan Specifications, Form of Contract and Estimate of Cost for the South Trunk Sewer Extension – Phase 3 Project. Approved 5-0
- G. Motion by Highfill, seconded by Goode to approve **Resolution 2020-46** Resolution Awarding Contract for the South Trunk Sewer Extension – Phase 3 Project. Approved 5-0
- H. Motion by Hungerford, seconded by Highfill to approve **Resolution 2020-47** Resolution Approving the Contract and the Bond for the South Trunk Sewer Extension – Phase 3 Project, subject to Engineer's approval. Approved 5-0
- I. Motion by Hungerford, seconded by Cackler to approve **Resolution 2020-48** Approving Sanitary Sewer Easements for South Trunk Sewer Extension – Phase 3 and Authorizing Payment Therefore. Approved 5-0
- J. Mayor Tom Becker opened the **Public Hearing** on Amending the Code of Ordinances, City of Cumming Iowa by Amending Chapter 55 Animal Protection and Control at 7:02 p.m. Motion by Cackler, seconded by Hungerford to close the public hearing at 8:05 p.m. No public or written comments were made. Approved 5-0
- K. Motion by Hungerford, seconded by Goode to approve the first reading of **Ordinance 2020-03** Amending the Code of Ordinances, City of Cumming, IA by Amending Provisions pertaining to Chapter 55 Animal Protection and Control. Approved 5-0
- L. Mayor Tom Becker opened the **Public Hearing** on Amending the Code of Ordinances, City of Cumming Iowa by Amending Chapter 69.09 Truck Parking Limited at 7:02 p.m. Motion by Cackler, seconded by Highfill to close the public hearing at 8:10 p.m. No public or written comments were made. Approved 5-0.
- M. Motion by Hungerford, Seconded by Cackler to approve the first reading of **Ordinance 2020-04** Amending the Code of Ordinances, City of Cumming, IA by Amending Provisions pertaining to Chapter 69.09 Truck Parking Limited. Approved 5-0

- N. Motion by Ochanpaugh, seconded by Goode to approve **Resolution 2020-43** Accepting Public Infrastructure Improvements and Approving Final Plat of Great Western Crossing Plat 2. Approved 5-0
- O. Motion by Hungerford, seconded by Cackler, to approve **Resolution 2020-44** Accepting Public Infrastructure Improvements and Approving Final Plat of Great Western Crossing Plat 3. Approved 5-0
- P. Motion by Hungerford, seconded by Ochanpaugh to approve **Resolution 2020-45** Set a Date for Public Hearing to Amend the Code of Ordinances, City of Cumming, Iowa by Amending Chapter 90, Water Service System. Approved 5-0
- Q. Water Tower Art & Fundraising Update was held by Natasha Adams
- R. Motion by Cackler, seconded by Highfill to approve the final design of the Cumming Water Tower proposal subject to removal of the sign on the artwork. Approved 5-0
- S. **Resolution 2020-46** Licensing Agreement with Ben Schuh, Plum Forward was tabled.
- T. Motion by Highfill, seconded by Goode to accept the lowest bid for the Cumming Water Tower Boom Rental in the amount of \$2,161.80. Approved 5-0
- U. City Hall Propane Tank Painting Discussion was held. Motion by Cackler, seconded by Goode to approve the painting of the propane tank, base coat by Central Tank Coatings in the amount of \$500 and the design by artist Ben Schuh in the amount of \$750.00. Approved 5-0
- V. Retaining Wall Bid Discussion was held. Motion by Cackler, seconded by Ochanpaugh to table this discussion and to obtain more bids.

**Reports:** Council – Moving forward with City Administrator interviews, Request to include P&Z changes to Ordinances in Packet. Clerk – Request to inquire ABC Pest services for annual maintenance and hornets. Extending no Parking signs downtown.

**Public Comment:** Pat Whalen gave kudos to Deputy Clerk for keeping residents informed of current events in the City.

**Upcoming City Council Meetings:** Regular Council Meeting, August 10, 2020 at 7:00 p.m. at City Hall.

Motion made by Cackler, seconded by Goode to Adjourn at 8:39 pm. Approved 5-0.

---

Tom Becker, Mayor

---

Attest: Angie Ritchie, Deputy Clerk

**City of Cumming**  
**Planning and Zoning Commission Meeting**  
**July 28<sup>th</sup>, 2020 Minutes**

The Cumming Planning and Zoning Commission held scheduled meeting on July 28<sup>th</sup>, 2020 at 7:00 p.m at the Cumming City Hall

The meeting was called to order by Vice Chair, Matt Daniels, at 7:03 p.m.

**I. ROLL CALL**

Present: Jill Stanford, Don Paulin, Matt Daniels, Karen McKinney, Holly De Hamer

Absent: Ethan Roos

**II. APPROVAL OF AGENDA**

Paulin moved – McKinney second - unanimously approved

**IV. CONSENT ITEMS**

June 23<sup>rd</sup>, 2020 Meeting Minutes

Paulin moved – McKinney second – unanimously approved

**V. ACTION/DISCUSSION ITEMS**

- A. Presentation – Diligent Development Park Proposal: Consent to move forward with concept as presented.
  
- B. Selection of Officers: Stanford moved – McKinney second – unanimously approved  
Don Paulin: Chair  
Karen McKinney: Vice Chair  
Holly De Hamer: Secretary
  
- C. Peddlers/Mobile Food Units/Special Event Permits: went over minor adjustments suggested by Cameron. Changed from 1 sign directing to mobile food unit to 2 signs.  
Paulin moved – McKinney second – unanimously approved
  
- D. Farmers Markets: subcommittee formed with Daniels, Paulin and De Hamer to present to the group at the next meeting. Everyone else to send comments to Paulin for compilation.
  
- E. Board Member Applicant Discussion: Agreed to recommend Jorydan Hill to city council for open position.  
Paulin moved – Stanford second – unanimously approved

**VI. Upcoming Planning A Zoning Meeting**

- A. Regular meeting August 25<sup>th</sup>, 2020 at 7:00 P.M. at City Hall

**VII. ADJOURN:**

Paulin moved – Stanford second – unanimously approved –Adjourned 9:10 PM

**Wage & Contribution Report**

Effective Date: 07/01/2020  
 Generated On: 08/03/2020 10:33:06  
 Due Date:2020-08-17  
 WAGE REPORT JULY 2020  
 Report Status: Released  
 Trans#: 120871170  
 Date Released: 08/03/2020  
 Member Count: 3  
 Report Source: ESS - manual

Employer Name: 91308 CITY OF CUMMING

**Wage History Summary**

Agreement	Occupation Code	Period Wages	Employer Contributions	Member Contributions	Funds Total
MONTHLY Cities	01-Regular	\$ 3,200.00	\$ 302.08	\$ 201.28	\$ 503.36
MONTHLY Cities	17-Part-time Elected Officials	\$ 844.82	\$ 79.76	\$ 53.14	\$ 132.90
<b>Totals</b>		<b>\$ 4,044.82</b>	<b>\$ 381.84</b>	<b>\$ 254.42</b>	<b>\$ 636.26</b>

**Cash Summary**

Fund	Due	Paid	Balance
Employer Contributions	\$ 381.84	\$ 0.00	\$ 381.84
Member Contributions	\$ 254.42	\$ 0.00	\$ 254.42
<b>Totals</b>	<b>\$ 636.26</b>	<b>\$ 0.00</b>	<b>\$ 636.26</b>

Wage & Contribution Report

Effective Date: 07/01/2020  
 Generated On: 08/03/2020 10:33:06  
 Due Date:2020-08-17  
 WAGE REPORT JULY 2020  
 Report Status: Released  
 Trans#: 120871170  
 Date Released: 08/03/2020  
 Member Count: 3  
 Report Source: ESS - manual

Employer Name: 91308 CITY OF CUMMING

Agreement	Occupation Code	Period Wages	Employer Contributions	Member Contributions	Funds Total
MONTHLY Cities	01-Regular	\$ 3,200.00	\$ 302.08	\$ 201.28	\$ 503.36
MONTHLY Cities	17-Part-time Elected Officials	\$ 844.82	\$ 79.76	\$ 53.14	\$ 132.90
Jul 1, 2020	BECKER, THOMAS B	\$ 685.44	\$ 64.71	\$ 43.11	\$ 107.82
Jul 1, 2020	HUNGERFORD, KATHIE E	\$ 159.38	\$ 15.05	\$ 10.03	\$ 25.08
Jul 1, 2020	RITCHIE, ANGIE	\$ 3,200.00	\$ 302.08	\$ 201.28	\$ 503.36
		\$ 4,044.82	\$ 381.84	\$ 254.42	\$ 636.26
Totals:		\$ 4,044.82	\$ 381.84	\$ 254.42	\$ 636.26



**City of Cumming**  
**Balance Sheet by Fund (Fiscal Year-to-Date)**  
 July 2020

	General Funds (Governmental Funds)	Road Use Tax (Special Revenue Funds)	Employee Benefits (Special Revenue Funds)	Emergency (Special Revenue Funds)
<b>ASSETS</b>				
Current Assets				
Checking/Savings	344,766.49	50,640.56	12,618.48	85.51
Total Current Assets	344,766.49	50,640.56	12,618.48	85.51
<b>TOTAL ASSETS</b>	<b>344,766.49</b>	<b>50,640.56</b>	<b>12,618.48</b>	<b>85.51</b>
<b>LIABILITIES &amp; EQUITY</b>	<b>248,828.74</b>	<b>54,004.31</b>	<b>12,885.33</b>	<b>186.20</b>

**City of Cumming**  
**Balance Sheet by Fund (Fiscal Year-to-Date)**  
 July 2020

	LOST (Special Revenue Funds)	TIF (Special Revenue Funds)	Total Special Revenue Funds (Governmental Funds)	Debt Service Funds (Governmental Funds)
<b>ASSETS</b>				
Current Assets				
Checking/Savings	142,964.57	23,208.97	229,518.09	8,204.14
Total Current Assets	142,964.57	23,208.97	229,518.09	8,204.14
<b>TOTAL ASSETS</b>	<b>142,964.57</b>	<b>23,208.97</b>	<b>229,518.09</b>	<b>8,204.14</b>
<b>LIABILITIES &amp; EQUITY</b>	<b>145,274.37</b>	<b>23,867.31</b>	<b>236,217.52</b>	<b>8,932.62</b>

**City of Cumming**  
**Balance Sheet by Fund (Fiscal Year-to-Date)**  
 July 2020

	Total Governmental Funds	Water Operating (Water)	Water Project (Water)	Total Water (Proprietary Funds)
<b>ASSETS</b>				
Current Assets				
Checking/Savings	582,488.72	208,436.53	127,821.43	336,257.96
<b>Total Current Assets</b>	<b>582,488.72</b>	<b>208,436.53</b>	<b>127,821.43</b>	<b>336,257.96</b>
<b>TOTAL ASSETS</b>	<b>582,488.72</b>	<b>208,436.53</b>	<b>127,821.43</b>	<b>336,257.96</b>
<b>LIABILITIES &amp; EQUITY</b>	<b>493,978.88</b>	<b>224,541.10</b>	<b>127,821.43</b>	<b>352,362.53</b>

**City of Cumming**  
**Balance Sheet by Fund (Fiscal Year-to-Date)**  
 July 2020

	Sewer Operating (Sewer)	Sewer Phase 1 (Sewer)	Sewer Phase 2 (Sewer)	Total Sewer (Proprietary Funds)
<b>ASSETS</b>				
Current Assets				
Checking/Savings	74,888.15	7,792.03	94,443.41	177,123.59
<b>Total Current Assets</b>	<b>74,888.15</b>	<b>7,792.03</b>	<b>94,443.41</b>	<b>177,123.59</b>
<b>TOTAL ASSETS</b>	<b>74,888.15</b>	<b>7,792.03</b>	<b>94,443.41</b>	<b>177,123.59</b>
<b>LIABILITIES &amp; EQUITY</b>	<b>70,351.29</b>	<b>7,792.03</b>	<b>94,443.41</b>	<b>172,586.73</b>

**City of Cumming**  
**Balance Sheet by Fund (Fiscal Year-to-Date)**  
 July 2020

---

	Total Proprietary Funds	Unclassified	TOTAL
<b>ASSETS</b>			
Current Assets			
Checking/Savings	513,381.55	-76,388.48	1,019,481.79
Total Current Assets	513,381.55	-76,388.48	1,019,481.79
<b>TOTAL ASSETS</b>	<b>513,381.55</b>	<b>-76,388.48</b>	<b>1,019,481.79</b>
<b>LIABILITIES &amp; EQUITY</b>	524,949.26	553.65	1,019,481.79

**City of Cumming**  
**Claims Paid & Summary of Receipts (Last Month)**  
 July 2020

Type	Date	Num	Name	Memo	Amount
<b>0001110 · Operating Checking</b>					
Check	07/09/2020	5997	Ben Schuh		-5,255.00
Check	07/09/2020	5990	Midamerican Energy		-70.31
Check	07/09/2020	5981	Goode Jr, Larry	mileage & back meetings	-73.62
Check	07/09/2020	5996	Waste Connections		-2,251.64
Check	07/09/2020	5987	Combined Systems ...		-7.49
Check	07/09/2020	5984	Ritchie, Angie		-16.04
Check	07/09/2020	5988	ICAP	liability insurance	-3,960.77
Check	07/09/2020	5989	Iowa DNR	FY21 annual water supply fee	-40.09
Check	07/09/2020	5991	N/Warren Town & C...	June 18 & June 25 publications	-175.59
Check	07/09/2020	5992	Office Depot	office supplies	-65.27
Check	07/09/2020	5993	Pro-Image Sign & Lig...	banners	-76.00
Check	07/09/2020	5994	Sternquist	final payment on road project	-4,770.18
Check	07/09/2020	5995	Veenstra & Kimm Inc.	engineering costs	-22,156.66
Check	07/09/2020	5985	Cardmember Service		-16.90
Check	07/09/2020	5986	City of Des Moines	WRA Payment	-6,650.00
Check	07/13/2020	Transfer	mm to Checking		34,000.00
Check	07/13/2020	Transfer	mm to Checking		5,000.00
Deposit	07/14/2020			Deposit	56.25
Deposit	07/17/2020			Utility Deposit	4,758.45
Paycheck	07/20/2020	5998	Ritchie, Angie		-1,225.00
Check	07/20/2020	6003	US Bank		-11.86
Check	07/20/2020	5999	ClerkBooks, Inc.	Remainder of software fee	-1,980.00
Check	07/20/2020	6000	Midamerican Energy		-634.05
Check	07/20/2020	6001	Office Depot	office supplies	-95.71
Check	07/20/2020	6002	Skinner Law Office PC	legal fees 5/7-7/7	-10,325.78
Deposit	07/21/2020			Road Use Tax Deposit	3,363.75
Deposit	07/29/2020			LOST Deposit	2,309.80
Deposit	07/30/2020			Property Tax Deposit	4,907.61
Deposit	07/30/2020			void check 5877	16,000.00
Deposit	07/30/2020			void check 5981	73.62
Check	07/30/2020	Transfer	Checking to mm		-9,000.00
Total 0001110 · Operating Checking					1,611.52
<b>0001112 · Money Market</b>					
<b>General Fund</b>					
Check	07/13/2020	Transfer			-34,000.00
Check	07/13/2020	Transfer			-5,000.00
Check	07/30/2020	Transfer			9,000.00
Total General Fund					-30,000.00
Total 0001112 · Money Market					-30,000.00
<b>TOTAL</b>					<b>-28,388.48</b>

11:11 AM

08/07/20

**City of Cumming**  
**Claims To Be Approved**  
All Transactions

---

Type	Date	Num	Name	Memo	Amount
Check	08/07/2020		Contractor Sales & S...	Water Tower Lift	-970.00
Check	08/07/2020		Waste Connections	July 2020 Bill - Inv # 2964060	-2,251.64
Check	08/07/2020		City of Des Moines	WRA Payment - Invoice # 116184	-3,325.10
Check	08/07/2020		Ben Schuh	Balance of Water Tower Mural Project	-7,860.00
Check	08/07/2020		Craig Olson	Hometown Pride Banner Reimbursement	-42.79
<b>Total</b>					<b>-14,449.53</b>

---

**City of Cumming**  
**Deposit Detail**  
 July 2020

Type	Num	Date	Name	Account	Amount
Deposit		07/14/2020		0001110 · Operatin...	56.25
			Treasurer - State	Ask My Accountant	-56.25
TOTAL					-56.25
Deposit		07/17/2020		0001110 · Operatin...	4,758.45
			Des Moines Water ...	E · Charges for Serv...	-1,337.17
			Des Moines Water ...	E · Charges for Serv...	-815.27
			Des Moines Water ...	E · Charges for Serv...	-332.16
			Des Moines Water ...	E · Charges for Serv...	-2,251.80
			Des Moines Water ...	8106404 · Collection...	187.50
			Des Moines Water ...	2906404 · Collection...	32.40
			Des Moines Water ...	8156404 · Collection...	39.30
Payment	3228	07/17/2020	Simpson, Gin	Undeposited Funds	-181.25
Sales Receipt	2	07/17/2020	Misc Customer	Undeposited Funds	-25.00
Payment	5185	07/17/2020	Misc Customer	Undeposited Funds	-50.00
Payment	773707	07/17/2020	Misc Customer	Undeposited Funds	-25.00
TOTAL					-4,758.45
Deposit		07/21/2020		0001110 · Operatin...	3,363.75
			Treasurer - State	4430 · Road Use Ta...	-3,363.75
TOTAL					-3,363.75
Deposit		07/29/2020		0001110 · Operatin...	2,309.80
			Treasurer - State	4090 · Local Option ...	-2,309.80
TOTAL					-2,309.80
Deposit		07/30/2020		0001110 · Operatin...	4,907.61
			Treasurer - County	4000 · Property Tax...	-3,020.72
			Treasurer - County	4003 · Agricultural L...	-78.47
			Treasurer - County	4004 · Insurance Levy	-54.06
			Treasurer - County	4000 · Property Tax...	-100.69
			Treasurer - County	A2 · TIF Revenue	-658.34
			Treasurer - County	4000 · Property Tax...	-728.48
			Treasurer - County	4000 · Property Tax...	-266.85
TOTAL					-4,907.61
Deposit		07/30/2020		0001110 · Operatin...	16,000.00
			Central Tank Coatings	8106490 · Other Pro...	-16,000.00
TOTAL					-16,000.00
Deposit		07/30/2020		0001110 · Operatin...	73.62
			Goode Jr, Larry	6106240 · Meetings ...	-73.62
TOTAL					-73.62





### City of Cumming Transient Merchant Sales Registration

Company Name DamonLayne Woodworking

Address 1526 Iowa Avenue, Earlham, Iowa 50072

Applicant's Name Damon Argabright

Telephone No. 563-340-3722 Alternate No. \_\_\_\_\_

Vehicle Description and License Number 2015 Chevy 1500; ISU4552

Federal ID No. \_\_\_\_\_ IA. Retail Sales Tax Permit No. 161005636

Describe Business To Be Conducted in City of Cumming Vendor at Middlebrook Farm

Date (s) Business Is To Be Conducted July - Oct 2020

Address Where Business Is To Be Conducted Middlebrook Farm

The information on this form is correct and true to the best of my knowledge.

  
Merchant's Signature

7/15/20  
Date

TO BE COMPLETED BY THE CITY OF CUMMING:

RECEIVED JUL 20 2020

Filing Fee Amount \$25.00 per day/per person Date Paid \_\_\_\_\_

This registration verifies that the above person, firm, corporation, vendor, salesperson or organization has complied with all the requirements of the City of Cumming to conduct temporary business within the City. Upon request, the Merchant shall present a copy of this registration.

Date Issued \_\_\_\_\_ Date of Expiration \_\_\_\_\_

By \_\_\_\_\_, Deputy City Clerk

City of Cumming  
Transient Merchant Sales Registration

Company Name Iowa Family Chiropractic

Address 1906 Ingersoll Ave. Des Moines, IA 50309

Applicant's Name Kirstin Angus DOB 02/14/1993

Telephone No. 515-446-1530 Alternate No. 515-401-2305

Vehicle Description and License Number White GMC Acadia 435 ZDB

Federal ID No. 263684005 IA. Retail Sales Tax Permit No. 177113787

Describe Business To Be Conducted in City of Cumming Attending the Middlebrook Farm as a vendor to do touchless back screenings.

Date(s) Business Is To Be Conducted 7/17/20, 8/7/20, 8/28/20, 9/11/20, 10/2/20, 10/23/20, 10/30/20

Address Where Business is to Be Conducted Middlebrook Farm

The information on this form is correct and true to the best of my knowledge. By signing you acknowledge you have completed all necessary licenses and/or bonding that is required to operate your business within the state of Iowa.

Kirstin Angus 7/13/2020  
Merchant's Signature Date

---

TO BE COMPLETED BY THE CITY OF CUMMING:

Filing Fee Amount \$25.00 per person

Date Paid 7/16/20

This registration verifies that the above person, firm, corporation, vendor, salesperson or organization has complied with all the requirements of the City of Cumming to conduct temporary business within the City. Upon request, the Merchant shall present a copy of this registration.

Date Received 7/13/20

Date BC Completed 7/16/20

BC Approve  Deny

Date Issued \_\_\_\_\_

Date of Expiration \_\_\_\_\_

By \_\_\_\_\_, Deputy City Clerk

# CITY OF CUMMING

## APPLICATION TO SERVE ON A CITY BOARD OR COMMISSION

Name: Jordyn Hill Occupation: Recorders Clerk - Polk County Recorder  
Address: 8988 42nd Ln Cumming, IA 50061  
Best Phone Number to Reach You: 515-473-5835  
Email: jordynmhill@live.com  
How long have you been a resident? Cumming resident since October 2015

- I am interested in serving on the following Board/Commission:

Planning and Zoning Board Member

List Board/Commission you currently serve on: Parish Council - St. John's the <sup>(7 years)</sup> Apostle Catholic Church

List Board/Commission you have served on in the past: Norwalk Library Board (5 years)

Describe why you are interested and what knowledge and/or experience you have that would be beneficial to the community.

- I have been a Cumming Resident for over 4 years and before that was a Norwalk Resident for 26 years, born & raised. I saw information about the opening on the Planning & Zoning Board on the Cumming Facebook page. I would like to be considered for the Board Member position.

- I have previously worked in the Insurance industry at Nationwide Insurance for 5 years. I also held a position at Principal in finance, before accepting a position for Polk County in the Real Estate Division within the Recorders Office. I have been with Polk County for 5 1/2 years.

- My position within the Recorders Office is a Recorders Clerk - I am responsible for making sure that the real estate documents meet formatting standards. I am the platting specialist - I look through all platting materials for new subdivisions and condominiums. That work includes working on city easements, restrictions, ordinances, resolutions, any and all documents that are recorded in the county for a new subdivision plats. I work on and record 100-150 new plats a year.

- I have previously sat on the Library Board in Norwalk. I was on the Norwalk Library Board for 5 years until I moved out of city limits to Cumming.

- I am also on the Parish Council at St. John's the Apostle Catholic Church. I have been on the board for almost 7 years and have organized several fundraiser events both big and small. I have been the head of several sub-committees - specifically with the current plan for expansion.

I am passionate about my community and would love the opportunity to contribute by way of the Planning & Zoning board member.

Signature

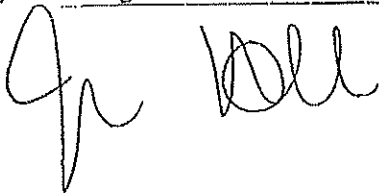

Date

2/27/2020

Please return to:

Cumming City Hall  
PO Box 100, 649 N 44<sup>th</sup> St, Cumming, IA 50061  
cityclerk@cumming-iowa.com

# A Garden for Community & Play

## *The Park at Great Western Crossing*

Original Park Design \_ July 7, 2020  
Revision #1 \_ July 28, 2020  
Revision #2 \_ August 3, 2020  
Revision #3 \_ August 5, 2020 (Per Parks Board Approval)

Thomas Henderson  
Attorney at Law - Whitfield & Eddy  
henderson@whitfieldlaw.com

Adam Mekies, PLA  
Harvard GSD, Urban Design  
amekies@gsd.harvard.edu

Todd Lehman  
Design Guy, Cre8 Play  
todd@cre8play.com

# A Garden for Community & Play

## *The Park at Great Western Crossing*

### FINAL UPDATES Per Parks Board Comments on 8/4/2020.

- Minor Lawn - in place of community garden plots in this park. Community garden plots were discussed as part of the HOA, rather than in the publicly maintained and operated park.
- Larger Shelter intent and scale approved per photo and information included.
- Restroom + Fountain Floor plan + Elevation approved in intent, scale, and configuration. General aesthetic preferred siding as the exterior material.
- Parking reviewed and approved as shown.

\*Overall Masterplan of the Park was approved by the Cumming Parks Board with these notes on items reviewed.



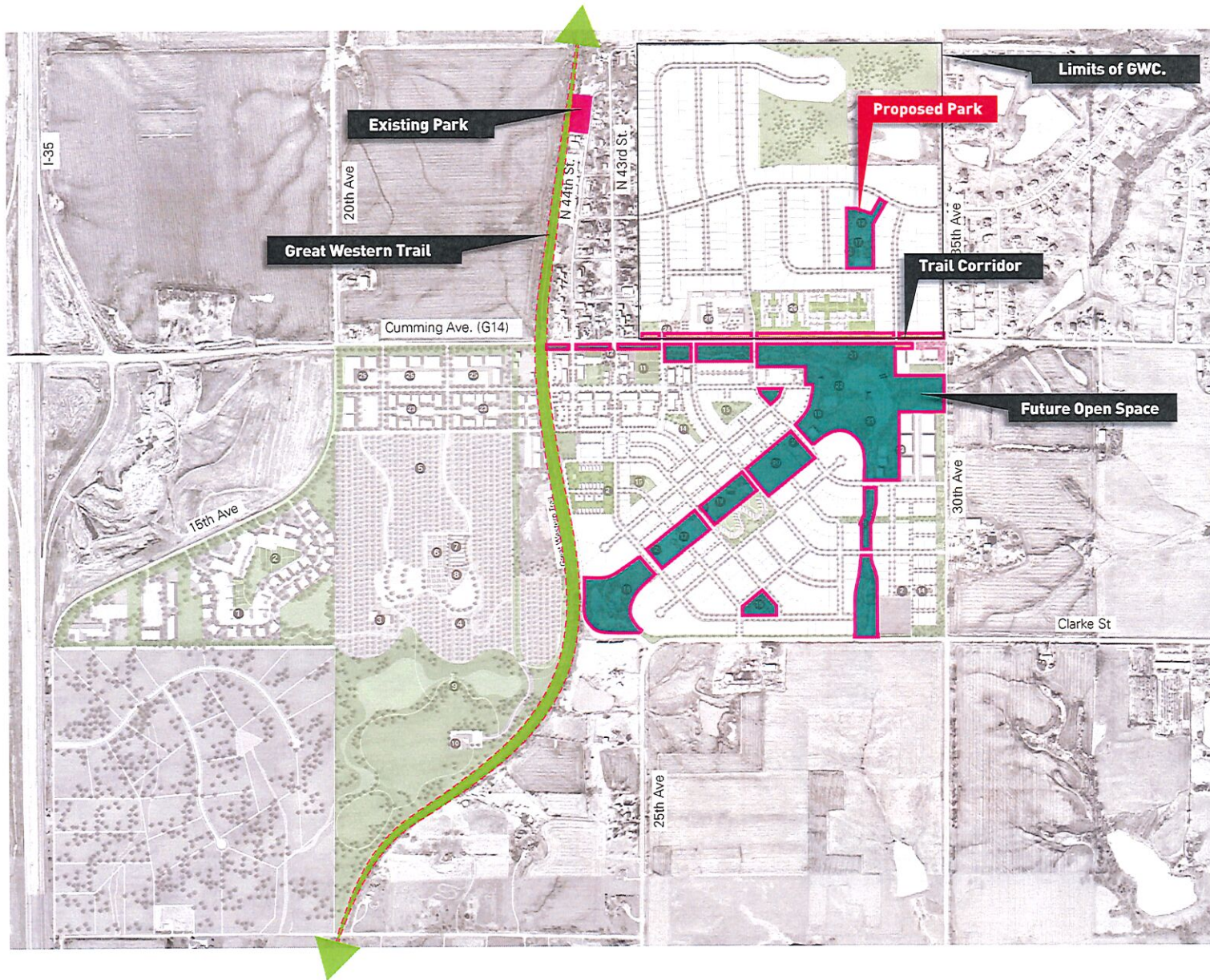

# Starting A Parks Network

Middlebrook is a very large, complex, and long term project. These diagrams are a conceptual draft, and are not a final representation of any intent beyond the limits of Great Western Crossing (GWC.)

The intent of this document is to demonstrate the future potential of program, ecology, recreation, and connectivity in the long term parks and open-space system at large.

**The Park at GWC. is the first of many more parks, open-spaces, and programmatic opportunities to come. The park will endeavor to serve as broad an audience for the town of Cumming at large, while recognizing that larger ecological, recreational and more active programmatic opportunities will come.**



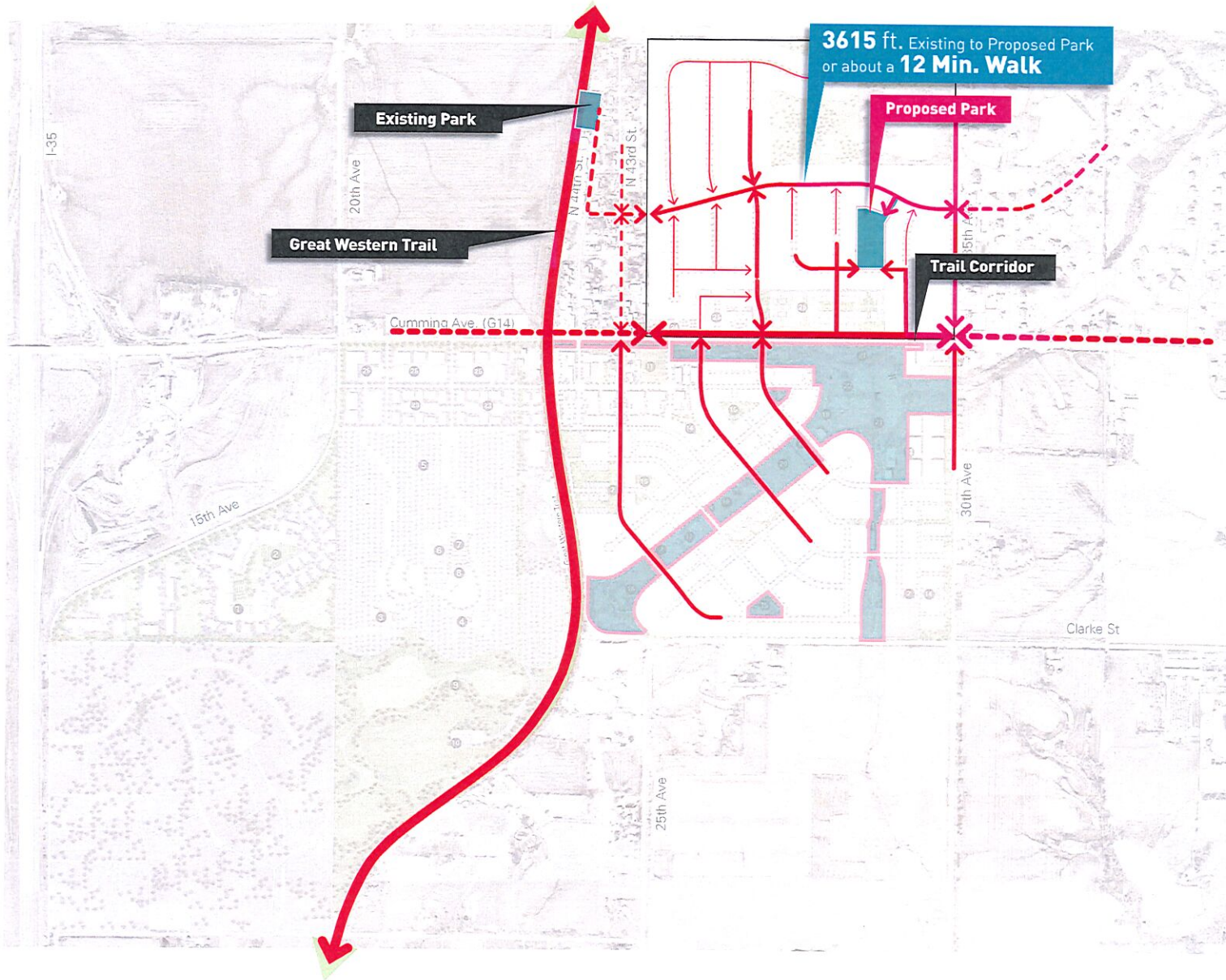

# Starting An Access Network

Middlebrook is a very large, complex, and long term project. These diagrams, and are not a final representation of any intent beyond the limits of Great Western Crossing (GWC.)

All public right-of-ways / streets in GWC. have been designed with proper sidewalk connections and on-street bike-way connectivity due to the residential nature and low traffic volume expectations, exceeding the requirements of all approved PUD stipulations.

This diagram depicts the primary routes of connectivity within the proposed contexts of development. This is not a completed set of circulation routes in the Middlebrook Context south of G-14, but simply demonstrating a few of the initial key connections in the plan.





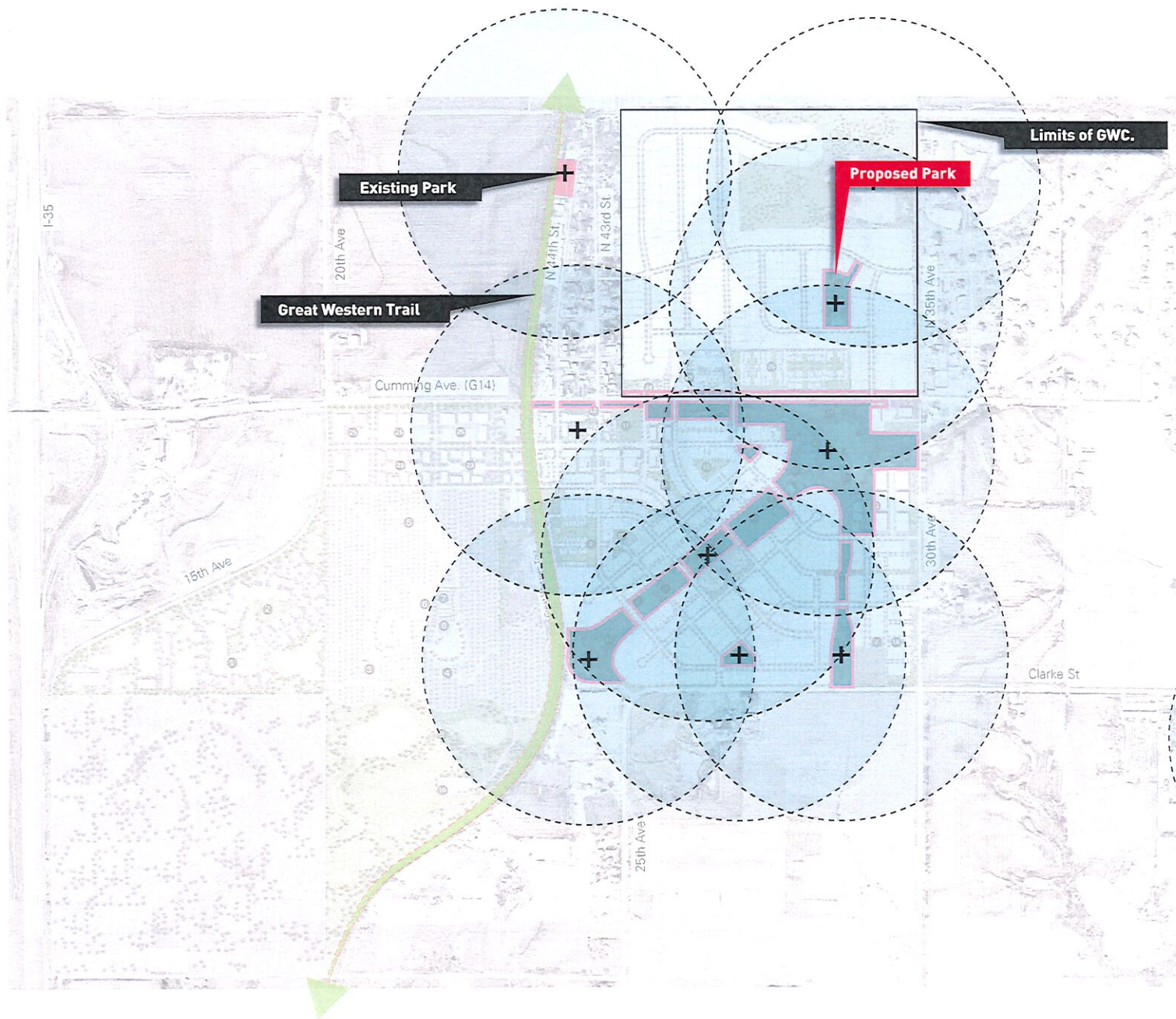

# Taking A 5 Minute Walk

Middlebrook is a very large, complex, and long term project. These diagrams are a conceptual draft, and are not a final representation of any intent beyond the limits of Great Western Crossing (GWC.)

**GOAL:**  
 100% OF ALL RESIDENTS WILL BE WITHIN A 5 MINUTE WALK OF A PARK OR OPEN SPACE AREA.

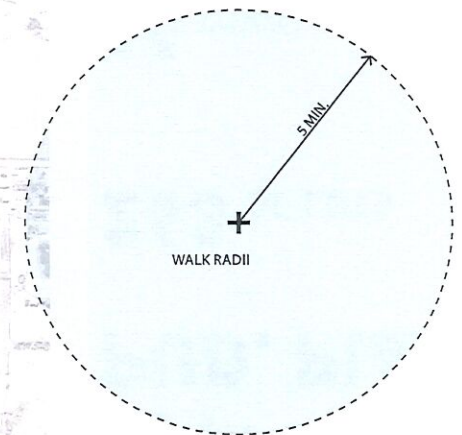

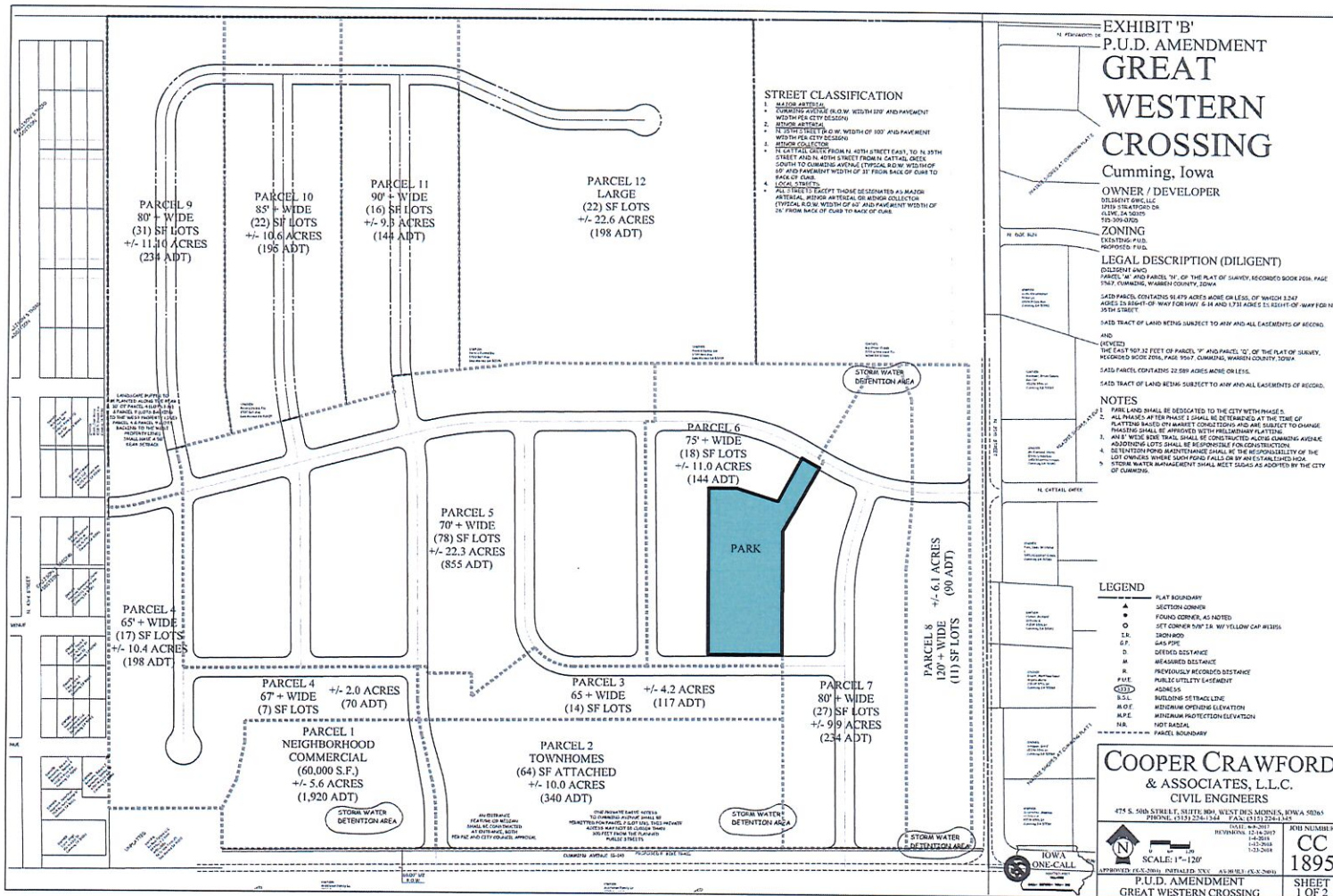

# Approved PUD. Plan

263 SF LOTS

64 TOWN HOMES

60,000 SF  
Neighborhood Commercial

**1 Park**  
Three Acres

# GWC. in a typ. Market

Fantastic Context

Fantastic Homes



**263** SF LOTS  
\$300K Each

**64** TOWN HOMES  
\$220K Each

**60,000 SF**  
Neighborhood  
Commercial

---

**\$92,980,000**  
Taxable Value

Investment  
Within Builds Value for  
Public Realm

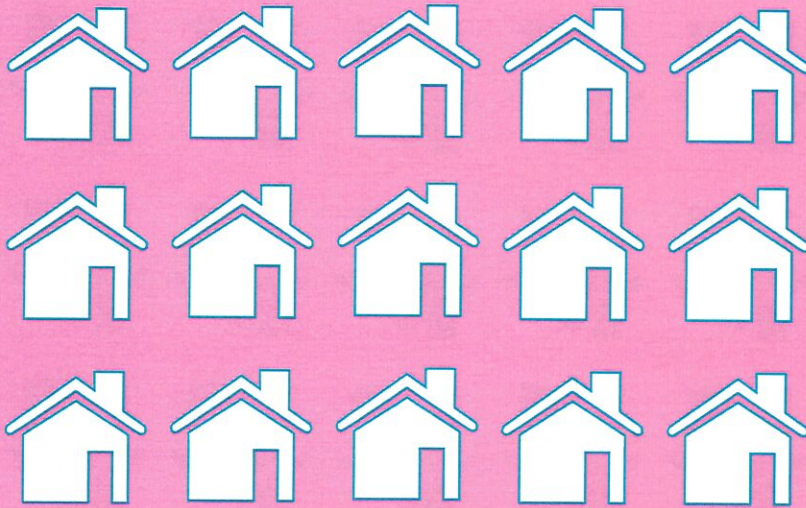

## GWC. in Middlebrook

**263** SF LOTS  
\$400K Each

**64** TOWN HOMES  
\$300K Each

**60,000 SF**  
Neighborhood  
Commercial

---

**\$124,400,000**  
Taxable Value

# Updated Site Plan



## PROGRAM SUMMARY

- A) 2-5 Playground
- B) 5-12 Playground
- C) Multi-Age Swings
- D) Shade Shelter + Seating Patio
- E) Performance Patio / Stage Area
- F) Multi-Purpose Field
- G) Smaller Lawn / Picnic Zone
- H) Fruit Tree Orchards
- I) Shade Groves
- J) River Birch Groves
- K) Seating Along Path
- L) Restroom Facility + Fountain
- M) Parking Lot
- N) Public Access Connection
- O) Perimeter Park Trails
- P) Shrub Groves

Playground Zone  
See Playground  
Specific Drawings



# Trails & Parking

## LEGEND

Paved Walks 8' Wide  
1510 feet long

Paved Walks 5' Wide  
275 feet long

Parking Lot  
(20 Spaces + 1 ADA Van)

Adjacent Sidewalks

Sharow  
(Bike-able Streets)

Playground Zone  
See Playground  
Specific Drawings

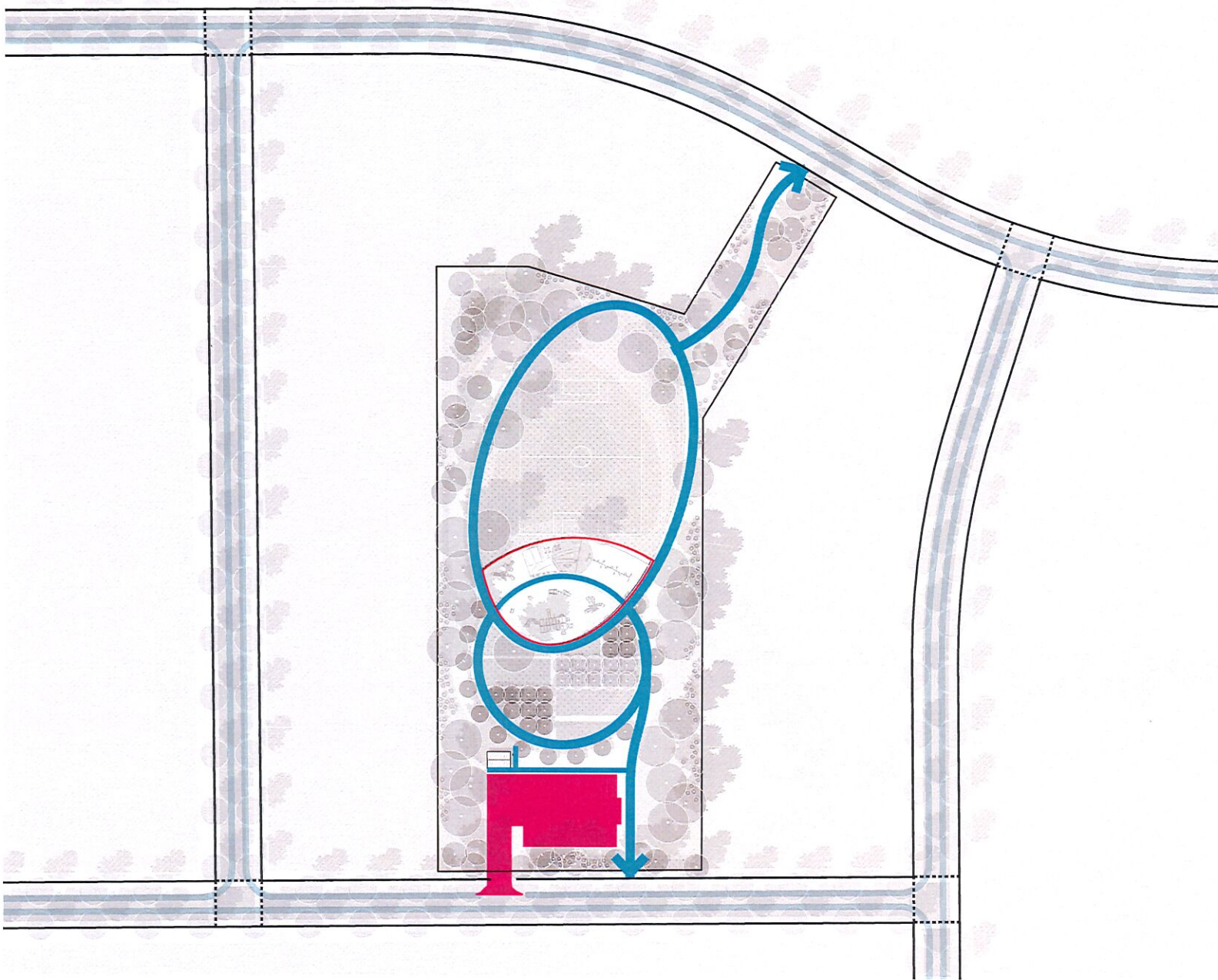

# Trees + Shade

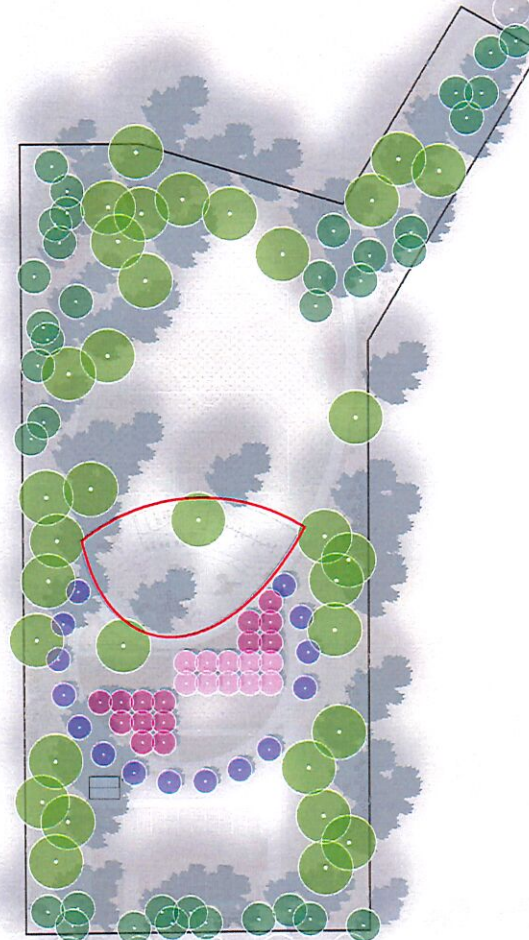

## LEGEND



Overstory Trees  
Swamp White Oak  
Northern Red Oak  
Kentucky Coffee Tree



Birch Groves  
River Birch (Single-Stem)  
River Birch (Multi-Stem)



Flowering Fruit Trees  
Crab Apple 'Adirondak'



Cherry 'Northstar'



Cherry 'Meteor'

Playground Zone  
See Playground  
Specific Drawings



# Planting + Ground Plane

## LEGEND

- Turf lawn (Mown)  
.75 Acres 
- Shortgrass Meadow  
*Mown Twice Per / Year* 
- Riparian Meadow  
*Mown Twice Per / Year* 
- Smaller Lawn (Mown)  
*Orchard + Picnic* 
- Paved Areas 
- Shrub Plantings  
*Red Twig Dogwood*  
*Blackhaw Viburnum*  
*Half-High Blueberry 'Polaris' + 'North Blue'* 
- Playground Zone  
*See Playground Specific Drawings* 





# Projected Schedule & Key Milestones

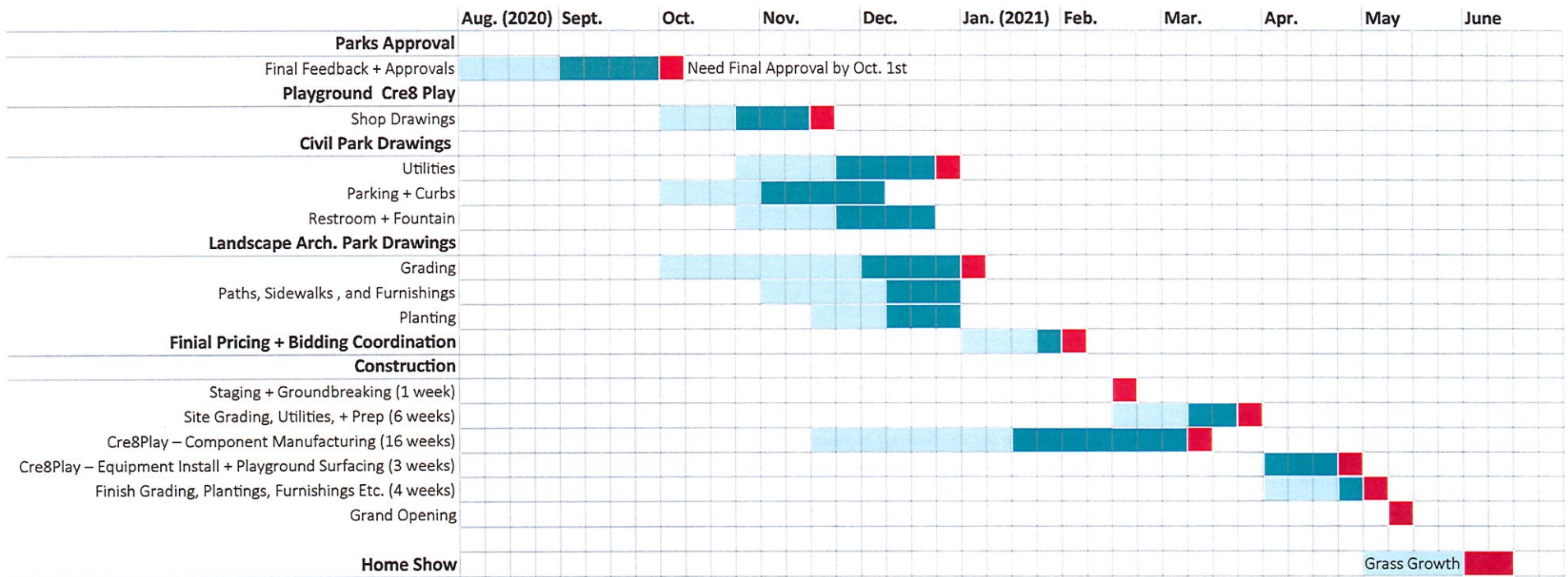



**Priest Point Park Shelter #1, Olympia WA**  
**Roughly 25 ft x 35 ft**

**Fits 6-10 Picnic Tables**

**Gable Roof (Double slope)**

*Conceptual Estimate - \$85,000*  
*To be confirmed at Bid prior to TIF agreement*

# Park Shelter (larger)

The described desire was for a larger park shelter than the small shade structure that was in the July 28th Plans.

*See on the left (2) Conceptual options which would allow for the park to function as previously drawn but add a larger shelter in the patio / performance space area. Labels (D+E) on the Site Illustrative Plan.*

Assumed Utilities + Features

- Night Safety Lighting
- Electrical Power Supply
- Picnic Tables
- Concrete footings + patios
- Bike Racks

# Park Rest Room

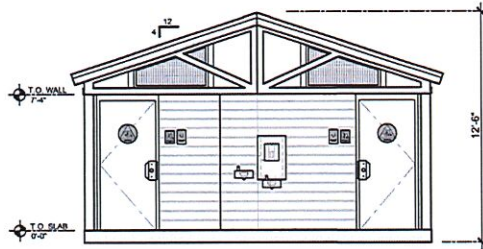

## ELEVATION

SCALE: 1/8"=1'0"

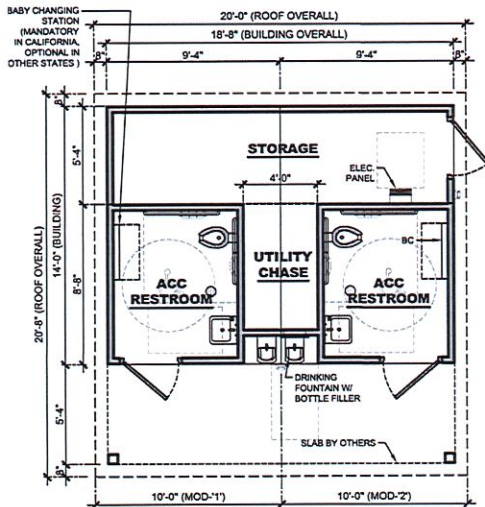

## FLOOR PLAN

SCALE: 1/8"=1'0"

NOTE: STAINLESS FIXTURES

The described desire was for additional information of what would be included in the parks plans.

*See on the left current conceptual option of a pre-fab facility with (2) restrooms and maintenance storage area. As well as water fountain location.*

**Materials would be an exterior siding, wood front frames, and dark metal roofing to match the aesthetic of park shelter and play structures.**

Conceptual Estimate:  
Pre-Fab Cost Installed on Site  
\$210,000 + On-site Footings \$8,000

*To be confirmed at Bid prior to TIF agreement*

# Parking Capacity + Code

## Minimum Number of Accessible Parking Spaces

2010 Standards (208.2)

Total Number of Parking Spaces Provided in Parking Facility (per facility)	(Column A) Minimum Number of Accessible Parking Spaces (car and van)	Minimum Number of Van-Accessible Parking Spaces (1 of six accessible spaces)
1 to 25	1	1
26 to 50	2	1
51 to 75	3	1
76 to 100	4	1
101 to 150	5	1
151 to 200	6	1
201 to 300	7	2
301 to 400	8	2
401 to 500	9	2
500 to 1000	2% of total parking provided in each lot or structure	1/6 of Column A*
1001 and over	20 plus 1 for each 100 over 1000	1/6 of Column A*

\*one out of every 6 accessible spaces

Our current parking lot includes:

- 20 Parking Spaces
- 1 ADA Van Parking Space.

Iowa SUDAS Standards do not provide requirements for Openspace Landuses and Parking.

City of Houston:

1.0 parking space for the first 2 acres and 1.0 parking space for each additional acre and additional parking spaces must be provided for each separate use classification constructed in the park.

(3) based on acres  
+ 10 based on uses  
= 13 Per Houston Standards



130,680 SF of Park  
= 14 Per Placer County Standards



Placer County California:

1 per 10,000 sq. ft. of use area of Parks + Playgrounds.



*Half Log Bench*



*Hay Bale Bench*

# Seating Along Path

## 2-5 Playground

Playground for toddlers or preschoolers encourage skill development through interactive play, sensory experiences, challenging activities, imagination and independence.



# 5-12 Playground

Kids ages 5 to 12 need physical and mental challenges while they play. Fun farm themed playground equipment for 5- to 12-year-olds help them develop balance, coordination, muscle endurance, problem-solving skills, social skills and much more.



# 5-12 Playground

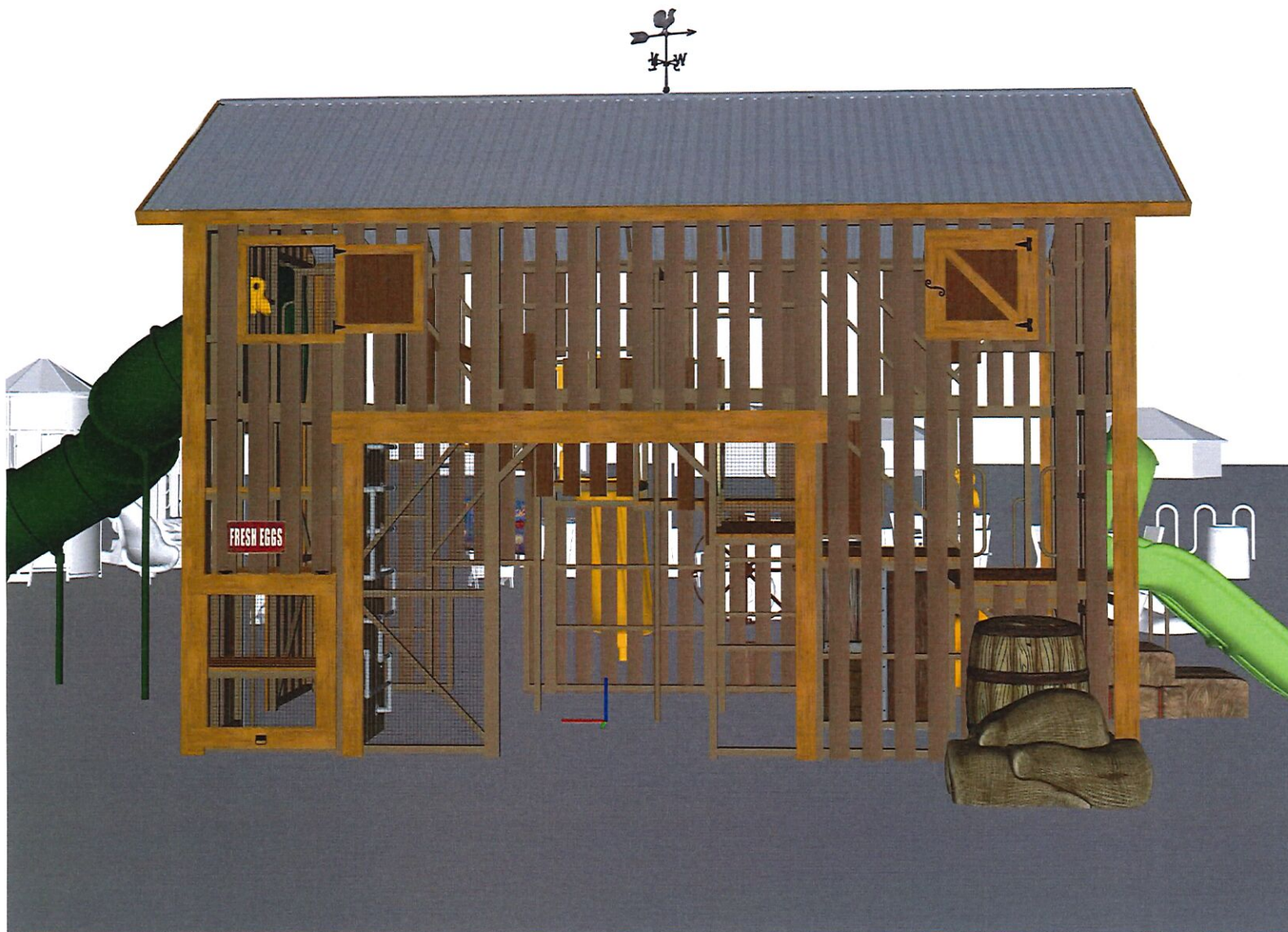

Unique Play Barn brings fun to new heights with multiple climbing opportunities and exhilarating sliding. Innovative climbers invite kids to scale the outside up to the various height decks up to 8'.

It also gives kids plenty of unique ways to look out, while mesh panels and wide slotted composite wood siding provide visibility from the outside.





*Accessible Swing Seat*



*Enclosed Tot Seat*



*Belt Swing Seat*

# Multi-Age Swings

Swings have long been a playground staple and they continue to offer hours of fun and physical activity for children of all ages.

We providing a wide variety of models sized right for kids ages 2 to 12.



# Value in Depth, Complexity & Collaboration

*City of Cumming, Iowa*



..... KOETHE PROPERTY..... MIDDLETON FAMILY.....



Middlebrook



Brewery at  
Middlebrook

Homestead at  
Middlebrook



COOPER CRAWFORD  
& ASSOCIATES, L.L.C.  
CIVIL ENGINEERS &  
LAND SURVEYORS



WE WHITFIELD  
& EDDY LAW

DESIGNWORKSHOP

Hogan Law Office

FARMER D  
CONSULTING

SITE INNOVATIONS [ lab ]

trost  
DEVELOPMENT  
SERVICES



**Water Tower Art Update**  
**August 10, 2020**

# Topics

1. Cost Update
2. License Agreement
3. Fundraising
4. Community Party / Unveiling Event

# Cost Update

<b>Item Description</b>	<b>Budget</b>	<b>Cost</b>
Central Tank *	\$16,000	\$16,500
Artist Fee *	\$15,720	\$16,470
Boom Lift Rental	\$2,800	\$970
<b>Total</b>	<b>\$34,520</b>	<b>\$33,940</b>
<b>Grants Approved</b>	<b>\$13,225</b>	
<b>From CHTP 2020 Budget</b>	<b>\$2,605</b>	
* Includes propane tank		

# License Agreement

- Committee recommends the one time license fee of \$7,500.
  - Eliminates record keeping and periodic payments to Ben Schuh
  - City keeps all donations and fundraising monies received

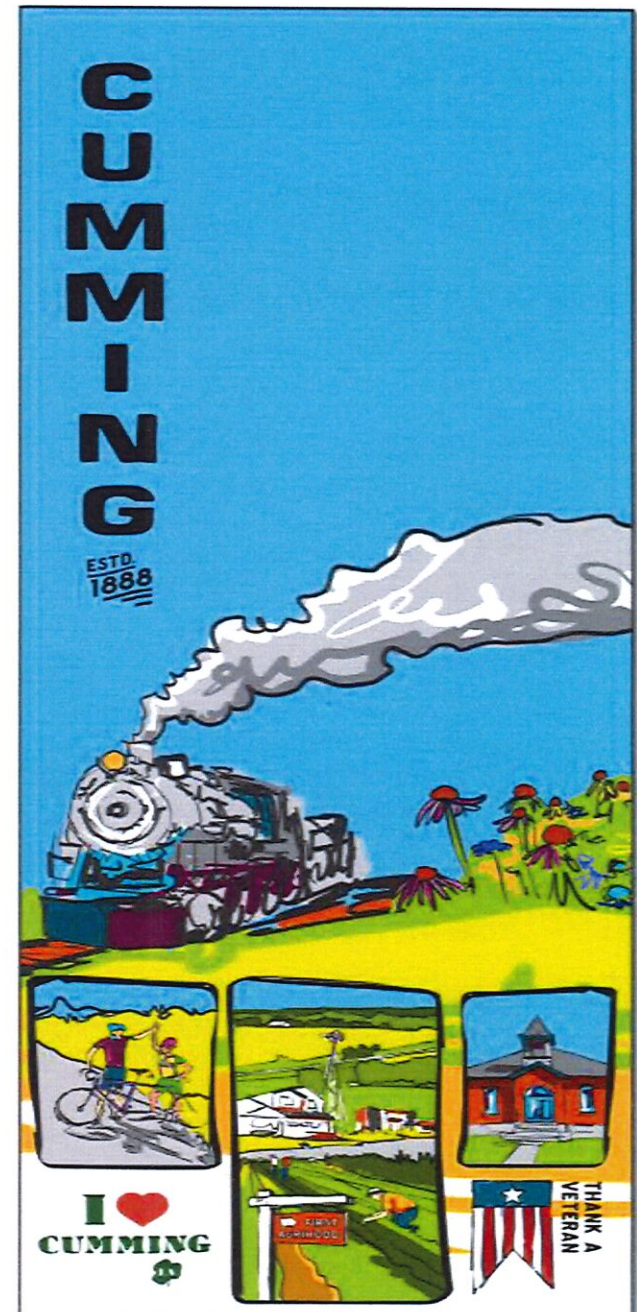

# Fundraising

- **Committee is ready to start fundraising / donation process.**
- **First group of items:**
  - Quality T-shirts
  - Quality posters
  - Polar water bottles
- **Future items:**
  - Bike jersey
  - Koozies
  - Pint glasses
  - Shot glasses
- **Potential co-marketing opportunities with Distillery, Cumming Tap, Diligent Development**
- **Businesses and residents sponsorships and donations.**

# Fundraising

- **Committee wants start ordering fundraising items using approved 2021 CHTP budget.**
- **Committee asks City Council to authorize the Deputy Clerk to pay vendor bills, not to exceed \$1,500 in total, upon presentation of invoices.**
- **Committee recommends establishing a sale page on the City's website.**
  - City will set up a PayPal or Square account to receive payments
  - Linked to a City bank account
- **Committee has a booth at Fridays at the Farm to sell fundraising items.**



# Community Party / Unveiling Event

- CHTP will work with the Park and Recreation Board to schedule and host the event.
- Plaque recognizing major sponsors
- Thinking early October
- Invitees - Residents, City Council, Mayor, Artist, Warren County Economic Development, Warren County Philanthropic Partnership, other Warren County Hometown Pride groups, media

**RESOLUTION 2020-50**  
**City of Cumming**

**AN AUTHORIZATION FOR PAYMENT OF HOMETOWN PRIDE VENDOR  
OBLIGATIONS NOT TO EXCEED \$1,500.00**

**WHEREAS**, The City Council believes it to be in the best interest of the City to authorize the City Clerk/Deputy Clerk to pay certain vendor obligations prior to Council approval, and which will be brought before the Council at the next council meeting for approval,

**NOW THEREFORE BE IT RESOLVED BY THE CITY COUNCIL OF THE CITY OF CUMMING, IOWA AS FOLLOWS:**

1. The City Clerk/Deputy Clerk is hereby authorized to pay certain obligations prior to Council approval, provided said obligations are vendors submitted by the Hometown Pride Committee for fundraising purposes and in total will not exceed \$1,500.
  
2. This Resolution shall be effective immediately and the Clerk is authorized to implement upon its final passage and approval, as provided by law.

Passed by the City Council of the City of Cumming, Iowa this 10<sup>th</sup> day of August, 2020, and approved by the Mayor of the City of Cumming, Iowa this 10<sup>th</sup> day of August, 2020.

\_\_\_\_\_  
Tom Becker, Mayor

ATTEST:

\_\_\_\_\_  
Angie Ritchie, Deputy Clerk

**RESOLUTION 2020-51**

**LICENSE AGREEMENT**

**BETWEEN**

**BEN SCHUH, PLUM FORWARD, AND CITY OF CUMMING**

This License Agreement (Agreement) is entered into between an individual, Ben Schuh, and the Iowa Corporation, Plum Forward, (collectively listed hereunder as the “Artist”), and the City of Cumming (“Cumming”), an Iowa municipality (collectively the “Parties”).

WHEREAS, the Parties have executed an agreement entitled Cumming Water Tower Mural (the “Mural Agreement”) dated June 8, 2020;

WHEREAS, Artist’s interests in the Works rendered and provided in fulfillment of the Mural Agreement are protected by United States copyrights, and Artist desires to license those Works on a limited, nonexclusive basis to Cumming; and,

WHEREAS, Cumming desires to obtain a limited, nonexclusive license for the Work created by Artist;

NOW, THEREFORE, in consideration of the mutual promises and covenants and good and valuable consideration, the receipt of which is hereby acknowledged, the Parties agree as follows:

**1. Definitions.** As used in this Agreement, the following terms shall have the following meanings:

- 1.1 “Work” shall mean the design, digital concepts, finished product, and depictions of the finished product as it relates to the artwork installed as a mural by Artist on the water tower structure located at or about 649 N 44th Street in Cumming, Iowa, that is licensed under this Agreement and the subject of the Mural Agreement referenced herein.
- 1.2 “Derivative Work(s)” shall mean any reproduction, depictions, or imagery that either (a) constitutes a derivative work of the Mural within the meaning of that term under the United States copyright law or (b) produces an image with a visual effect that would infringe the copyright in the visual effect contained in the Mural.
- 1.3 “Derivative Product” shall mean any product or medium that is based on or derived from the Mural or any visual effect produced by the Mural.

**2 License of Work.** Artist does hereby grant and convey to Cumming, subject to all the terms and conditions in this Agreement, a nonexclusive, worldwide license to sublicense, to sell, to edit, to publish, and to distribute to others any Derivative Works and Derivative Products of the Work. This license shall include the right to create, to sublicense, to sell, to edit, to publish, and to distribute to others Derivative Works and Derivative Products of said Work.

**3 Representations and Indemnity by Artist.**

- 3.1 Artist represents and warrants to Cumming that (a) the Work is original and does not infringe upon any copyright or other proprietary rights of others; (b) Artist is the sole and exclusive owner of all rights in the Work; and (c) Artist has full power to enter into this Agreement, to carry out its obligations herein, and to grant the rights herein granted to Cumming.
- 3.2 Artist shall indemnify Cumming and its duly authorized agents and sublicensees for, and hold them harmless from, any loss, expense (including reasonable attorneys' fees), damage, or liability arising out of any claim, demand, or suit resulting from a breach of any of the warranties in Section 3.1 of this Agreement. Cumming shall promptly inform Artist in writing of any such claim, demand, or suit, and Artist shall fully cooperate in the defense thereof.
- 3.3 Cumming shall have the right to extend Artist's representations and warranties and indemnities contained herein to Cumming's customers and sublicensees, and Artist shall be liable to the same extent as if such representations and warranties were made by Artist directly to such customers and sublicensees.
- 3.4 Artist grants no rights and makes no warranties with regard to the use of names, trademarks, trade dress, or registered, unregistered, or copyrighted designs or works of art or architecture depicted in the Work, and Cumming must satisfy itself that all the necessary rights or consents regarding any of the foregoing as may be required have been obtained.

#### **4 Representations and Indemnity by Cumming.**

- 4.1 Cumming represents and warrants that it shall market the Work and will make all reasonable efforts to fundraise through distributions of Derivative Products and Derivative Works through sales, distribution, publication, and/or sublicenses as long as there is an outstanding balance on the licensing fee listed herein.
- 4.2 Cumming represents and warrants that it shall not sell, distribute, publish, or sublicense any of the Work and shall restrict any sale, distribution, publication, or sublicense to any party or for any use that would damage the reputation of Artist or hold Artist in ill repute. Without limiting the previous sentence, Cumming shall not permit any pornographic, defamatory, libelous, or otherwise unlawful use of the Work whether directly or in context or juxtaposition with the Work.
- 4.3 Cumming shall indemnify Artist and its customers and sublicensees for, and hold them harmless from, any loss, expense (including reasonable attorneys' fees), damage, or liability arising out of any claim, demand, or suit resulting from a breach of any of the warranties in Sections 4.1 and 4.2 above. Artist shall promptly inform Cumming in writing of any such claim, demand, or suit, and Artist shall fully cooperate in defense thereof.

#### **5 Copyrights.**

- 5.1 Except as stated herein and for the purpose of fulfilling this Agreement, no ownership of copyright in the Work shall pass to Cumming by this Agreement. Copyright ownership shall remain with Artist at all times. Cumming is strictly

prohibited from using, distributing, publishing, or sublicensing the Work in any manner except as permitted under this Agreement. Upon demand by Artist, Cumming shall immediately assign to Artist any copyright resulting from a Derivative Work arising under this Agreement.

5.2 A mark that credits Artist shall appear adjacent to any Work utilized in an editorial manner. The crediting mark shall be in a form suitable to Artist.

## **6 Infringement.**

6.1 Cumming will notify Artist of any actual, potential, or threatened infringement of the rights in the Work or Derivative Works that come to its attention.

6.2 In the event of any infringement of any rights granted to Cumming under this Agreement, Cumming shall have the first option to bring any such action for such infringement on behalf of itself and Artist, and Artist shall cooperate fully with Cumming in such action. In such event, Cumming shall bear the expenses of the action and shall recover its expenses from any sums recovered in the action. The balance of any proceeds of such action shall be divided between Cumming and Artist in a mutually agreeable allocation.

6.3 If Cumming declines in writing to bring any such action, Artist may proceed with an action for infringement and shall bear all expenses of the action and shall recover its expenses from any sums recovered in the action. The balance of such recovery, if any, shall be paid solely to Artist.

## **7 Term and Termination.**

7.1 This Agreement shall have an initial term of 1 year from the date of signing of this Agreement. This Agreement automatically extends for an indefinite term upon the provision of fees as outlined in Section 8 below unless either party notifies the other no later than 30 days before the termination of the Agreement that the party intends to terminate the Agreement.

7.2 This Agreement may be terminated by either party if

7.2.1 the other party commits or allows to be committed any material breach of the Agreement and fails to remedy such breach within 30 days of written notice having been given by the other party requiring the breach to be remedied or

7.2.2 the other party shall be dissolved or in any case shall commit any act of bankruptcy, shall have a receiving order made against it, or shall make or negotiate for any composition or arrangement with or assignment for the benefit of its creditors.

7.3 Termination shall be without prejudice to any rights or remedies that either party may have under this Agreement or otherwise.

7.4 Upon termination of this Agreement, Cumming shall

- 7.4.1 immediately provide a full and complete accounting to Artist of all Works and Derivative Works or Derivative Products that had previously been and currently are in Cumming's possession and
- 7.4.2 avail itself to future requests by providing a full and complete accounting to Artist of all Works and Derivative Works or Derivative Products within 30 days of Artist's written request for such records.

## **8 Licensing Fees.**

### **Licensing Option 1: Flat Fee w/Reduced Amount**

Cumming shall pay a one-time licensing fee of \$7,500.00, due upon completion of the completion of the Work by Artist as contemplated in the Cumming Water Tower Mural Agreement dated June 8, 2020. Upon receipt by the Artist of the licensing fee, Cumming shall be granted a perpetual license to sublicense, sell, edit, publish and distribute any Derivative Works and Derivative Products of the Work.

### **Licensing Option 2: 50% of Net Profits, capped at \$10k/5 Years**

#### **8.1 Installments**

- 8.1.1 Cumming shall have 5 years from the signing date of this agreement to pay the total licensing fee of \$10,000.00 (Installment Fee) to Artist. Upon receipt by the Artist of the total licensing fee, Cumming shall be granted a perpetual license to sublicense, sell, edit, publish and distribute any Derivative Works and Derivative Products of the Work.
- 8.1.2 Until the fee of \$10,000.00 is paid and satisfied, Cumming shall pay to Artist 50% of Cumming's net profits from proceeds for each sale, publication, and/or sublicense affiliated with the Works. Such payments shall be paid on the 20th day of January, April, July, and October.
- 8.1.3 At the time of payment, Cumming shall deliver to Artist a report that shall provide all reasonably necessary information for computation of the payments for the period which is reflected by the payment.
- 8.1.4 Artist or any agent of Artist may, upon reasonable notice and during normal business hours, inspect the records of Cumming on which such reports are based no more often than once per year, provided that such records shall remain confidential.
- 8.1.5 In the event that the total payments due are less than the \$10,000.00 (Installment Fee) any obligation for Cumming shall end 60 months from the signing date of this agreement, and all rights shall remain reserved by Artist.

- 8.2 Cumming may pay the \$10,000.00 licensing fee in advance of the five-year deadline without penalty or accounting.

**9 Additional Works.** Artist may, but is not obligated to, offer to Cumming additional works for licensing.

**10 Liability.**

10.1 Neither party shall be liable to the other with respect to any failure to perform its obligations under the Agreement arising from, but only to the extent of, circumstances beyond its control, including but not limited to force majeure, act of God, governmental act, fire, explosion, accident, civil commotion, terrorism, labor disputes of whatever nature and whatever cause, sabotage, breakdown of equipment, or the impossibility of obtaining materials.

10.2 Except as provided in Sections 3.2 and 4.3 of this Agreement, neither party shall be liable to the other for incidental, consequential, special, or punitive damages, including but not limited to loss of profits or goodwill.

**11 Interpretation and Construction.**

11.1 This Agreement may be amended only in a writing signed by both parties with a document that indicates on its face that it is amending this Agreement. E-mail correspondence shall not constitute an amendment to this Agreement unless each party's respective e-mail mirrors the other's terms of amendment and expressly states to each other that the correspondence is intended as an amendment to this Agreement.

11.2 Clause headings are inserted for convenience of reference only and shall have no effect on the construction of the Agreement.

11.3 This transaction shall be governed by the laws of the State of Iowa without resort to its conflict-of-laws provisions. The parties further agree that notice given pursuant to Section 12 of this Agreement shall be sufficient notice for the purpose of service of process for any lawsuit brought under this Agreement.

11.4 Nothing herein shall be deemed or construed as creating a joint venture or partnership between Cumming and Artist, and neither is authorized as an agent or other representative of the other.

11.5 No failure, delay, or indulgence on the part of either party in exercising any power or right conferred on such party by the Agreement shall operate as a waiver of such power or right.

11.6 This Agreement contains all of the agreements, understandings, representations, warranties, and conditions and constitutes the entire agreement between the parties pertaining to the subject matter hereof and supersedes all prior communications or agreements, written or oral.

**12 Notices.**

12.1 Any notice required to be given by one party to the other in accordance with the

Agreement shall be in writing and delivered by mail, courier, personal delivery, facsimile, or e-mail to the relevant party at the addresses listed below or such other address as shall have been notified to the other party and shall be deemed to have been delivered upon the earlier of receipt or the second business day after sending.

12.2 Notice to Cumming:

City of Cumming  
649 N. 44<sup>th</sup> St, PO Box 100, Cumming, IA 50061  
deputyclerk@cumming.iowa.gov  
515-981-9214

12.3 Notice to Artist:

Ben Schuh  
PO Box 409  
Polk City, IA 50226  
515-491-4909  
ben@plumforward.com

**13 Assignment.** This Agreement may not be assigned in total or in part by either party unless the other party agrees to such assignment in writing prior to such assignment.

By signing below, the parties represent that they have the authority to bind their respective entities and that they agree to the terms and conditions herein stated.

City of Cumming

By: \_\_\_\_\_  
Title: \_\_\_\_\_  
Date: \_\_\_\_\_, 20\_\_\_\_

Ben Schuh, Individually

\_\_\_\_\_  
Date: \_\_\_\_\_, 20\_\_\_\_

Plum Forward

By: \_\_\_\_\_  
Title: \_\_\_\_\_  
Date: \_\_\_\_\_, 20\_\_\_\_



# **NOTICE OF PUBLIC HEARING**

## **CITY OF CUMMING**

### **AMENDING CHAPTER 90 WATER SERVICE SYSTEM**

Notice is hereby given that the City Council of the City of Cumming, Iowa, will conduct a public hearing on Monday, August 10, 2020, 7:00 P.M., at City Hall, 649 N. 44<sup>th</sup> Street, Cumming, Iowa, to receive comments on the following:

Amending the City of Cumming's Code of Ordinances,  
Chapter 90 Water Service System

Additional information regarding this request may be obtained by contacting the Deputy Clerk at 981-9214.

Anyone wishing to comment on this matter should attend this hearing or submit written comments at any time prior to the hearing. Send comments to City of Cumming, P. O. Box 100, Cumming, IA, 50061

# ORDINANCE 2020-05

## AN ORDINANCE AMENDING THE CODE OF ORDINANCES OF THE CITY OF CUMMING, IOWA, BY AMENDING PROVISIONS PERTAINING TO CHAPTER 90 WATER SERVICE SYSTEM

BE IT ENACTED by the City Council of the City of Cumming, Iowa:

**SECTION 1. SECTION ADDED.** Section 90.12 of the Code of Ordinances of the City of Cumming, Iowa, is added to Chapter 90.

### 90.12 SHARING OF MAIN COSTS.

Where there are properties being developed that are separated by public access or streets and the properties can be served by one water main, Des Moines Water Works shall determine the side of the street on which the main will be located. The cost of installation of the main shall be borne by the developer who first develops the adjacent public access. Any person, firm or corporation who develops the property on the opposite side of the public access shall be required to pay the developer who originally installed said main, one-half the per foot cost of the installation times the number of frontage feet owned by the person, firm or corporation desiring to make said connection, subject to the following:

1. The initial developer shall provide documentation of all costs related to installation of the main to the City prior to acceptance of final plat.
2. No reimbursement shall be made after the expiration of ten years from acceptance of the final plat.
3. Any person, firm or corporation which becomes insolvent or ceases to do business after the signing of an agreement contemplated by this policy shall not be entitled to reimbursement and any agreement shall become null and void.

**SECTION 2. SEVERABILITY CLAUSE.** If any section, provision, or part of this ordinance shall be adjudged invalid or unconstitutional, such adjudication shall not affect the validity of the ordinance as a whole or any section, provision, or part thereof not adjudged invalid or unconstitutional.

**SECTION 3. WHEN EFFECTIVE.** This ordinance shall be in effect from and after its final passage, approval, and publication as provided by law.

Passed and Approved by the Council the \_\_\_\_ day of \_\_\_\_\_, 2020.

\_\_\_\_\_  
Tom Becker, Mayor

ATTEST:

\_\_\_\_\_  
Angie Ritchie, Deputy Clerk

First Reading:

Second Reading:

Third Reading:

I certify that the foregoing was published as Ordinance 2020-05 on the \_\_\_\_ day of \_\_\_\_\_, 2020.

\_\_\_\_\_  
Angie Ritchie, Deputy Clerk

## CHAPTER 90

## WATER SERVICE SYSTEM

90.01 Definitions	90.07 Compliance with Plumbing Code
90.02 Mandatory Connections	90.08 Plumber Required
90.03 Water Service Provided by Des Moines Water Works	90.09 Failure to Maintain
90.04 Permits	90.10 Completion by the City
90.05 Fees and Charges	90.11 Operation of Curb Stop and Hydrants
90.06 Collections and Liens	

**90.01 DEFINITIONS.** The following terms are defined for use in the chapters in this Code of Ordinances pertaining to the Water Service System:

1. "Combined service account" means a customer service account for the provision of two or more utility services.
2. "Customer" means, in addition to any person receiving water service from the City, the owner of the property served, and as between such parties the duties, responsibilities, liabilities and obligations hereinafter imposed shall be joint and several.
3. "Des Moines Water Works" means the City water utility organized under Chapter 388, *Code of Iowa*, which is officially known as the Board of Water Works Trustees of the City of Des Moines, Iowa.
4. "Superintendent" means the Des Moines Water Works.
5. "Water main" means a water supply pipe provided for public or community use.
6. "Water service pipe" means the pipe from the water main to the building served.
7. "Water system" means all public facilities for securing, collecting, storing, pumping, treating and distributing water.

**90.02 MANDATORY CONNECTIONS.** All residences and business establishments within the City limits intended or used for human habitation, occupancy or use shall be connected to the public water system, if it is reasonably available and if the building is not furnished with pure and wholesome water from some other source.

**90.03 WATER SERVICE PROVIDED BY DES MOINES WATER WORKS.** Water service to all customers, within and without the City, that are connected to the water system of the City shall be provided by the Des Moines Water Works, from and after January 1, 2007, pursuant to the terms of a Chapter 28E Agreement between the City and the Des Moines Water Works. All such service shall be provided directly by Des Moines Water Works as the water service provider to customer and shall be pursuant to the rates, fees, rules, and regulations established by the Des Moines Water Works from time to time.

**90.04 PERMITS.** Before any person makes a connection with the public water system, a written permit must be obtained from the Des Moines Water Works as provided in its rules and regulations.

**90.05 FEES AND CHARGES.** Fees and charges for permits, taps, connections, and all other services, including system development fees, shall be established by, and collected by, the Des Moines Water Works.

**90.06 COLLECTIONS AND LIENS.** The Des Moines Water Works shall have, and may exercise, all authority for collection of water rates and charges granted by law, including discontinuing service and imposition of liens as provided by law.

**90.07 COMPLIANCE WITH PLUMBING CODE.** The installation of any water service pipe and any connection with the water system shall comply with all pertinent and applicable provisions, whether regulatory, procedural or enforcement provisions, of the International Plumbing Code.

**90.08 PLUMBER REQUIRED.** All installations of water service pipes and connections to the water system shall be made by a plumber licensed by the State, except that Des Moines Water Works shall be allowed to make routine service line repairs in connection with water main repairs.

**90.09 FAILURE TO MAINTAIN.** When any portion of the water service pipe, which is the responsibility of the property owner, becomes defective or creates a nuisance, and the owner fails to correct such nuisance, the Des Moines Water Works may do so, and the City may assess the costs thereof to the property.

**90.10 COMPLETION BY THE CITY.** Should any excavation be left open or only partly refilled for 24 hours after the water service pipe is installed and connected with the water system, or should the work be improperly done, the City shall have the right to finish or correct the work, and the Council shall assess the costs to the property owner or the plumber. If the plumber is assessed, the plumber must pay the costs before receiving another permit. If the property owner is assessed, such assessment may be collected with, and in the same manner as, general property taxes.

**90.11 OPERATION OF CURB STOP AND HYDRANTS.** It is unlawful for any person, except the Des Moines Water Works or authorized City personnel, to turn water on at the curb stop, and no person, unless specifically authorized by the City or the Des Moines Water Works, shall open or attempt to draw water from any fire hydrant for any purpose whatsoever.

**90.12 SHARING OF MAIN COSTS.**

Where there are properties being developed that are separated by public access or streets and the properties can be served by one water main, Des Moines Water Works shall determine the side of the street on which the main will be located. The cost of installation of the main shall be borne by the developer who first develops the adjacent public access. Any person, firm or corporation who develops the property on the opposite side of the public access shall be required to pay the developer who originally installed said main, one-half the per foot cost of the installation times the number of frontage feet owned by the person, firm or corporation desiring to make said connection, subject to the following:

4. The initial developer shall provide documentation of all costs related to installation of the main to the City prior to acceptance of final plat.
5. No reimbursement shall be made after the expiration of ten years from acceptance of the final plat.
6. Any person, firm or corporation which becomes insolvent or ceases to do business after the signing of an agreement contemplated by this policy shall not be entitled to reimbursement and any agreement shall become null and void.

[The next page is 405]

**ORDINANCE NO. 2020-02**

**AN ORDINANCE ADOPTING THE "CODE OF ORDINANCES OF THE CITY OF CUMMING, IOWA"**

BE IT ORDAINED by the City Council of the City of Cumming, Iowa, that:

SECTION 1. Pursuant to published notice and following public hearing on the 13th day of July, 2020, so required by Sections 362.3 and 380.8, Code of Iowa, there is hereby adopted by the City of Cumming, Iowa, the "CODE OF ORDINANCES OF THE CITY OF CUMMING, IOWA."

SECTION 2. All of the provisions of the "CODE OF ORDINANCES OF THE CITY OF CUMMING, IOWA," shall be in force and effect on and after the effective date of this ordinance.

SECTION 3. All ordinances or parts thereof in force on the effective date of this ordinance are hereby repealed from and after the effective date of this ordinance, except as hereinafter provided.

SECTION 4. The repeal provided for in the preceding section of this ordinance shall not affect any offense or act committed or done or any penalty or forfeiture incurred or any contract or right established or accruing before the effective date of this ordinance; nor shall such repeal affect any ordinance or resolution promising or guaranteeing the payment of money by the City or authorizing the issuance of any bonds of said City or any evidence of said City's indebtedness or any contract or obligation assumed by said City; nor shall said repeal affect the administrative ordinances or resolutions of the Council not in conflict or inconsistent with the provisions of "THE CODE OF ORDINANCES OF THE CITY OF CUMMING, IOWA"; nor shall it affect the following ordinances specifically saved from repeal:

**URBAN RENEWAL**

ORDINANCE NO.	ADOPTED	NAME OF AREA
2007-10	September 10, 2007	Cumming Commercial Urban Renewal Area

**VACATION AND DISPOSAL OF STREETS**

ORDINANCE NO.	ADOPTED	ORDINANCE NO.	ADOPTED
80-1		2006-04	March 13, 2006
96-4	November 14, 1995	2007-07	June 11, 2007
2000-02	November 8, 1999		

**ZONING MAP**

ORDINANCE No.	DATE ADOPTED	ORDINANCE No.	DATE ADOPTED
93-1	August 10, 1992	2007-03	May 31, 2007
98-2	August 25, 1997	2007-04	May 31, 2007
98-3	August 25, 1997	2007-05	May 31, 2007
2004-04	August 23, 2004	2007-06	May 31, 2007
2005-07	July 25, 2005	2015-03	November 23, 2015
2005-15	November 28, 2005	2016-03	October 10, 2016
2006-01	February 13, 2006	2016-04	October 26, 2016
2006-05	February 27, 2006	2018-03	April 23, 2018
2006-13	June 29, 2006	2018-05	July 9, 2018
2007-02	May 31, 2007		

nor shall it affect any other right or franchise conferred by any ordinance or resolution of the Council or any other person or corporation; nor shall it affect any ordinance naming, establishing, relocating or vacating any street or public way, whether temporary or permanent; nor shall it affect any ordinance amending the official zoning map, establishing building lines, establishing and changing grades, or dedicating property for public use; nor shall it affect any prosecution, suit or other proceeding pending or any judgment rendered on or prior to the effective date of this ordinance.

SECTION 5. The following ordinances, passed subsequent to the preparation of this code but prior to adoption of this code, are hereby adopted and made a part of this code. These are ordinances 2019-09 and 2019-10. Said ordinances shall be codified and incorporated in published copies of this code as supplements thereto following adoption of this ordinance.

SECTION 6. An official copy of the "CODE OF ORDINANCES OF THE CITY OF CUMMING, IOWA," adopted by this ordinance, including a certificate of the City Clerk as to its adoption and the effective date, is on file in the office of the City Clerk, and shall be kept available for public inspection.

SECTION 7. The City Clerk shall furnish a copy of the "CODE OF ORDINANCES OF THE CITY OF CUMMING, IOWA," to the Judicial Magistrates serving the City of Cumming.

SECTION 8. This ordinance shall be in full force and effect from and after the publication of this ordinance, as required by law.

Passed by the City Council of the City of Cumming, Iowa, the \_\_\_\_ day of \_\_\_\_\_, 2020.

\_\_\_\_\_  
Tom Becker, Mayor

ATTEST: \_\_\_\_\_  
Angie Ritchie, Deputy Clerk

First Reading: 7/13/20

Second Reading:

Third Reading:

#### CLERK'S CERTIFICATE

I hereby certify that the foregoing Ordinance No. 2020-02 was published as required by law on the \_\_\_\_ day of \_\_\_\_\_, 2020.

SIGNED \_\_\_\_\_  
Angie Ritchie, Deputy Clerk

# RECOMMENDATION BY THE PLANNING & ZONING COMMISSION

Recommendation:  Aye {Yes} 6  Nay {No} 0  
How Many How Many

ADD TWO NEW SECTIONS TO THE END OF  
CHAPTER 55 ANIMAL PROTECTION AND CONTROL.  
SECTION 55.16 SANITATION  
SECTION 55.17 LIMIT OFF NUMBER OF DOGS OR CATS ALLOWED  
- RECOMMENDED LANGUAGE ATTACHED

## Further Review Requested:

By Mayor/City Council  By City Attorney  By City Planner

## Additional Information:

COMMISSION'S RECOMMENDATION IS FOR A MAX OF FIVE (5)  
ANIMALS TOTAL BUT FINAL NUMBER MAY BE DISCUSSED  
BY COUNCIL MEMBERS.

## Requested Action To Be Taken By The City Council:

Motion  
 Resolution  
 Ordinance

Date: 6/4/20

Signature: 

Chair/Vice Chair/Secretary

Add to the end of Cumming Chapter 55

#### 55.16 SANITATION

It is the duty of every person owning or having custody or control of an animal to clean up, remove and dispose of the feces deposited by such animal upon public property, park property, public right-of-way or the property of another person.

#### 55.17 LIMIT OF NUMBER OF DOGS OR CATS ALLOWED

It shall be unlawful for an owner or occupant of a dwelling unit or residence, as defined in Chapter 165 of the Cumming Code, to harbor or house on or about the premises more than the following number of dogs and cats over the age of six months unless otherwise authorized in the Cumming Zoning Code.

1. Three dogs.
2. Three cats.
3. A combination of five dogs and cats.

Persons who own, possess, or keep more than five animals per household on the effective date of the ordinance codified in this section shall be permitted to continue to own, possess, or keep those animals only, but shall not be permitted to replace an animal which dies, is sold, transferred, or otherwise disposed of until the total number of animals per household is decreased to five.



# NOTICE OF PUBLIC HEARING

## CITY OF CUMMING

### AMENDING CHAPTER 55 ANIMAL PROTECTION AND CONTROL

Notice is hereby given that the City Council of the City of Cumming, Iowa, will conduct a public hearing on Monday, July 13, 2020, 7:00 P.M., at City Hall, 649 N. 44<sup>th</sup> Street, Cumming, Iowa, to receive comments on the following:

Amending the City of Cumming's Code of Ordinances,  
Chapter 55 Animal Protection and Control

Additional information regarding this request may be obtained by contacting the Deputy Clerk at 981-9214.

Anyone wishing to comment on this matter should attend this hearing or submit written comments at any time prior to the hearing. Send comments to City of Cumming, P. O. Box 100, Cumming, IA, 50061

# ORDINANCE 2020-03

## AN ORDINANCE AMENDING THE CODE OF ORDINANCES OF THE CITY OF CUMMING, IOWA, BY AMENDING PROVISIONS PERTAINING TO CHAPTER 55 ANIMAL PROTECTION AND CONTROL

**BE IT ENACTED** by the City Council of the City of Cumming, Iowa:

**SECTION 1. CHAPTER MODIFIED.** Chapter 55 of the Code of Ordinances of the City of Cumming, Iowa, is repealed and the following adopted in lieu thereof: See Attached Chapter 55 Animal Protection and Control.

**SECTION 2. SEVERABILITY CLAUSE.** If any section, provision, or part of this ordinance shall be adjudged invalid or unconstitutional, such adjudication shall not affect the validity of the ordinance as a whole or any section, provision, or part thereof not adjudged invalid or unconstitutional.

**SECTION 3. WHEN EFFECTIVE.** This ordinance shall be in effect from and after its final passage, approval, and publication as provided by law.

Passed and Approved by the Council the \_\_\_\_ day of \_\_\_\_\_, 2020.

\_\_\_\_\_  
Tom Becker, Mayor

ATTEST:

\_\_\_\_\_  
Angie Ritchie, Deputy Clerk

First Reading: 7/13/20

Second Reading:

Third Reading:

I certify that the foregoing was published as Ordinance 2020-03 on the \_\_\_\_ day of \_\_\_\_\_, 2020.

\_\_\_\_\_  
Angie Ritchie, Deputy Clerk

## CHAPTER 55

# ANIMAL PROTECTION AND CONTROL

55.01 Definitions	55.09 Vicious Dogs
55.02 Animal Neglect	55.10 Rabies Vaccination
55.03 Livestock Neglect	55.11 Owner's Duty
55.04 Abandonment of Cats and Dogs	55.12 Confinement
55.05 Livestock	55.13 At Large: Impoundment
55.06 At Large Prohibited	55.14 Disposition of Animals
55.07 Damage or Interference	55.15 Pet Awards Prohibited
55.08 Annoyance or Disturbance	

**55.01 DEFINITIONS.** The following terms are defined for use in this chapter.

1. "Advertise" means to present a commercial message in any medium including but not limited to print, radio, television, sign, display, label, tag or articulation.
2. "Animal" means a nonhuman vertebrate.  
*(Code of Iowa, Sec. 717B.1)*
3. "At large" means off the premises of the owner and not under the control of a competent person, restrained within a motor vehicle, or housed in a veterinary hospital or kennel.
4. "Business" means any enterprise relating to any of the following:
  - A. The sale or offer for sale of goods or services.
  - B. A recruitment for employment or membership in an organization.
  - C. A solicitation to make an investment.
  - D. An amusement or entertainment activity.
5. "Fair" means any of the following:
  - A. The annual fair and exposition held by the Iowa State Fair Board pursuant to Chapter 173 of the *Code of Iowa* or any fair event conducted by a fair under the provisions of Chapter 174 of the *Code of Iowa*.
  - B. An exhibition of agricultural or manufactured products.
  - C. An event for operation of amusement rides or devices or concession booths.
6. "Game" means a "game of chance" or "game of skill" as defined in Section 99B.1 of the *Code of Iowa*.
7. "Livestock" means an animal belonging to the bovine, caprine, equine, ovine or porcine species, ostriches, rheas and emus; farm deer as defined in Section 170.1 of the *Code of Iowa*; or poultry.  
*(Code of Iowa, Sec. 717.1)*
8. "Owner" means any person owning, keeping, sheltering or harboring an animal.
9. "Pet" means a living dog, cat, or an animal normally maintained in a small tank or cage in or near a residence, including but not limited to a rabbit, gerbil, hamster, mouse, parrot, canary, mynah, finch, tropical fish, goldfish, snake, turtle, gecko, or iguana.

**55.02 ANIMAL NEGLECT.** It is unlawful for a person who impounds or confines, in any place, an animal, excluding livestock, to fail to supply the animal during confinement with a sufficient quantity of food or water, or to fail to provide a confined dog or cat with adequate shelter, or to torture, deprive of necessary sustenance, mutilate, beat, or kill such animal by any means that causes unjustified pain, distress or suffering.

*(Code of Iowa, Sec. 717B.3)*

**55.03 LIVESTOCK NEGLECT.** It is unlawful for a person who impounds or confines livestock in any place to fail to provide the livestock with care consistent with customary animal husbandry practices or to deprive the livestock of necessary sustenance or to injure or destroy livestock by any means that causes pain or suffering in a manner inconsistent with customary animal husbandry practices.

*(Code of Iowa, Sec. 717.2)*

**55.04 ABANDONMENT OF CATS AND DOGS.** A person who has ownership or custody of a cat or dog shall not abandon the cat or dog, except the person may deliver the cat or dog to another person who will accept ownership and custody or the person may deliver the cat or dog to an animal shelter or pound.

*(Code of Iowa, Sec. 717B.8)*

**55.05 LIVESTOCK.** It is unlawful for a person to keep livestock of any kind other than that which is allowed by this Code of Ordinances or except in compliance with the City's zoning regulations. See Chapter 56 for Urban Chickens for permit requirements.

**55.06 AT LARGE PROHIBITED.** It is unlawful for any owner to allow an animal to run at large within the corporate limits of the City.

**55.07 DAMAGE OR INTERFERENCE.** It is unlawful for the owner of an animal to allow or permit such animal to pass upon the premises of another thereby causing damage to, or interference with, the premises.

**55.08 ANNOYANCE OR DISTURBANCE.** It is unlawful for the owner of a dog to allow or permit such dog to cause serious annoyance or disturbance to any person by frequent and habitual howling, yelping, barking, or otherwise, or by running after or chasing persons, bicycles, automobiles or other vehicles.

**55.09 VICIOUS DOGS.** It is unlawful for any person to harbor or keep a vicious dog within the City. A dog is deemed to be vicious when it has attacked or bitten any person without provocation, or when propensity to attack or bite persons exists and is known or ought reasonably to be known to the owner.

**55.10 RABIES VACCINATION.** Every owner of a dog shall obtain a rabies vaccination for such animal. It is unlawful for any person to own or have a dog in said person's possession, six months of age or over, which has not been vaccinated against rabies. Dogs kept in State or federally licensed kennels and not allowed to run at large are not subject to these vaccination requirements.

*(Code of Iowa, Sec. 351.33)*

**55.11 OWNER'S DUTY.** It is the duty of the owner of any dog, cat, or other animal that has bitten or attacked a person or any person having knowledge of such bite or attack to report this act to a local health or law enforcement official. It is the duty of physicians and veterinarians to report to the local board of health the existence of any animal known or suspected to be suffering from rabies.

*(Code of Iowa, Sec. 351.38)*

**55.12 CONFINEMENT.** If a local board of health receives information that an animal has bitten a person or that a dog or animal is suspected of having rabies, the board shall order the owner to confine such

animal in the manner it directs. If the owner fails to confine such animal in the manner directed, the animal shall be apprehended and impounded by such board, and after 10 days the board may humanely destroy the animal. If such animal is returned to its owner, the owner shall pay the cost of impoundment. This section does not apply if a police service dog or a horse used by a law enforcement agency and acting in the performance of its duties has bitten a person.

*(Code of Iowa, Sec. 351.39)*

**55.13 AT LARGE; IMPOUNDMENT.** Animals found at large in violation of this chapter shall be seized and impounded, or at the discretion of the peace officer, the owner may be served a summons to appear before a proper court to answer charges made thereunder.

**55.14 DISPOSITION OF ANIMALS.** When an animal has been apprehended and impounded, written notice shall be provided to the owner within two days after impoundment, if the owner's name and current address can reasonably be determined by accessing a tag or other device that is on or part of the animal. Impounded animals may be recovered by the owner upon payment of impounding costs, and if an unvaccinated dog, by having it immediately vaccinated. If the owner fails to redeem the animal within seven days from the date that the notice is mailed, or if the owner cannot be located within seven days, the animal shall be disposed of in accordance with law or destroyed by euthanasia.

*(Code of Iowa, Sec. 351.37, 351.41)*

**55.15 PET AWARDS PROHIBITED.**

*(Code of Iowa, Ch. 717E)*

1. Prohibition. It is unlawful for any person to award a pet or advertise that a pet may be awarded as any of the following:
  - A. A prize for participating in a game.
  - B. A prize for participating in a fair.
  - C. An inducement or condition for visiting a place of business or attending an event sponsored by a business.
  - D. An inducement or condition for executing a contract that includes provisions unrelated to the ownership, care or disposition of the pet.
2. Exceptions. This section does not apply to any of the following:
  - A. A pet shop licensed pursuant to Section 162.5 of the *Code of Iowa* if the award of a pet is provided in connection with the sale of a pet on the premises of the pet shop.
  - B. Youth programs associated with 4-H Clubs; Future Farmers of America; the Izaak Walton League of America; or organizations associated

with outdoor recreation, hunting or fishing, including but not limited to the Iowa Sportsmen's Federation.

**55.16 SANITATION**

It is the duty of every person owning or having custody or control of an animal to clean up, remove and dispose of the feces deposited by such animal upon public property, park property, public right-of-way or the property of another person.

**55.17 LIMIT OF NUMBER OF DOGS OR CATS ALLOWED**

It shall be unlawful for an owner or occupant of a dwelling unit or residence, as defined in Chapter 165 of the Cumming Code, to harbor or house on or about the premises more than the following number of dogs and cats over the age of six months unless otherwise authorized in the Cumming Zoning Code.

1. Three dogs.
2. Three cats.
3. A combination of five dogs and cats.

Persons who own, possess, or keep more than five animals per household on the effective date of the ordinance codified in this section shall be permitted to continue to own, possess, or keep those animals only, but shall not be permitted to replace an animal which dies, is sold, transferred, or otherwise disposed of until the total number of animals per household is decreased to five.

[The next page is 281]

# RECOMMENDATION BY THE PLANNING & ZONING COMMISSION

Recommendation:  Aye {Yes} 6  Nay {No} 0  
How Many How Many

REPLACE SECTION 69.09 OF CUMMING'S CODE WITH  
SECTION 69.09 OF NORWALK'S CODE.

- RECOMMENDED LANGUAGE ATTACHED

## Further Review Requested:

By Mayor/City Council       By City Attorney       By City Planner

## Additional Information:

THE RESTRICTION ON NOISE MAY BE DISCUSSED AND  
MODIFIED AS SEEN FIT BY COUNCIL MEMBERS.

## Requested Action To Be Taken By The City Council:

- Motion
- Resolution
- Ordinance

Date: 6/4/20

Signature: \_\_\_\_\_

Chair/Vice Chair/Secretary

Replace Section 69.09 of Cumming's code with 69.09 of Norwalk's code

#### CURRENT

Excepting only when such vehicles are actually engaged in the delivery or receiving of merchandise or cargo within the prohibited area, no person shall park or leave unattended a motor truck, semi-trailer, or other motor vehicle with trailer attached on any street within the Business District. When actually receiving or delivering merchandise or cargo, such vehicle shall be stopped or parked in a manner which will not interfere with other traffic. The provisions of this section do not apply to pick-up, light delivery or panel delivery trucks.

(Code of Iowa, Sec. 321.236[1])

#### REPLACEMENT

No person shall park a semi-tractor, semi-trailer, passenger bus used for commercial or school purposes, any vehicle in excess of five (5) tons, or other motor vehicle with trailer attached with total weight in excess of five (5) tons in violation of the following regulations.

(Code of Iowa, Sec. 321.236[1])

1. Streets. Excepting only when such vehicles are actually engaged in the delivery or receiving of merchandise or cargo, no person shall park or leave unattended such vehicle, on any street within the City except for designated parking areas on the City truck routes. When actually receiving or delivering merchandise or cargo such vehicle shall be stopped or parked in a manner which will not interfere with other traffic.

2. Noise. No such vehicle shall be left standing or parked upon any street, public or private parking lot, or drive of any service station between the hours of ten o'clock (10:00) p.m. and six o'clock (6:00) a.m. with the engine, auxiliary engine, air compressor, refrigerating equipment or other device in operation giving off audible sounds excepting only the drive of a service station when actually being serviced, and then in no event for more than thirty (30) minutes.

3. Livestock. No such vehicle containing livestock shall be parked on any street or highway for a period of time of more than thirty (30) minutes.



# **NOTICE OF PUBLIC HEARING**

## **CITY OF CUMMING**

### **AMENDING CHAPTER 69.09 TRUCK PARKING LIMITED**

Notice is hereby given that the City Council of the City of Cumming, Iowa, will conduct a public hearing on Monday, July 13, 2020, 7:00 P.M., at City Hall, 649 N. 44<sup>th</sup> Street, Cumming, Iowa, to receive comments on the following:

Amending the City of Cumming's Code of Ordinances,  
Chapter 69.09 Truck Parking Limited

Additional information regarding this request may be obtained by contacting the Deputy Clerk at 981-9214.

Anyone wishing to comment on this matter should attend this hearing or submit written comments at any time prior to the hearing. Send comments to City of Cumming, P. O. Box 100, Cumming, IA, 50061

# ORDINANCE 2020-04

## AN ORDINANCE AMENDING THE CODE OF ORDINANCES OF THE CITY OF CUMMING, IOWA, BY AMENDING PROVISIONS PERTAINING TO CHAPTER 69.09 TRUCK PARKING LIMITED

**BE IT ENACTED** by the City Council of the City of Cumming, Iowa:

**SECTION 1. CHAPTER MODIFIED.** Chapter 69.09 of the Code of Ordinances of the City of Cumming, Iowa, is repealed and the following adopted in lieu thereof: See Attached Chapter 69.09 Truck Parking Limited.

**SECTION 2. SEVERABILITY CLAUSE.** If any section, provision, or part of this ordinance shall be adjudged invalid or unconstitutional, such adjudication shall not affect the validity of the ordinance as a whole or any section, provision, or part thereof not adjudged invalid or unconstitutional.

**SECTION 3. WHEN EFFECTIVE.** This ordinance shall be in effect from and after its final passage, approval, and publication as provided by law.

Passed and Approved by the Council the \_\_\_\_ day of \_\_\_\_\_, 2020.

\_\_\_\_\_  
Tom Becker, Mayor

ATTEST:

\_\_\_\_\_  
Angie Ritchie, Deputy Clerk

First Reading: 7/13/20

Second Reading:

Third Reading:

I certify that the foregoing was published as Ordinance 2020-04 on the \_\_\_\_ day of \_\_\_\_\_, 2020.

\_\_\_\_\_  
Angie Ritchie, Deputy Clerk

## CHAPTER 69

# PARKING REGULATIONS

69.01 Park Adjacent to Curb	69.07 Persons with Disabilities Parking
69.02 Parking on One-Way Streets	69.08 No Parking Zones
69.03 Angle Parking	69.09 Truck Parking Limited
69.04 Manner of Angle Parking	69.10 Snow Removal
69.05 Parking for Certain Purposes Illegal	69.11 Snow Routes
69.06 Parking Prohibited	69.12 Loading Zones

**69.01 PARK ADJACENT TO CURB.** No person shall stand or park a vehicle in a roadway other than parallel with the edge of the roadway headed in the direction of lawful traffic movement and with the right-hand wheels of the vehicle within 18 inches of the curb or edge of the roadway except as hereinafter provided in the case of angle parking and vehicles parked on the left-hand side of one-way streets.

*(Code of Iowa, Sec. 321.361)*

**69.02 PARKING ON ONE-WAY STREETS.** No person shall stand or park a vehicle on the left-hand side of a one-way street other than parallel with the edge of the roadway headed in the direction of lawful traffic movement and with the left-hand wheels of the vehicle within 18 inches of the curb or edge of the roadway except as hereinafter provided in the case of angle parking.

*(Code of Iowa, Sec. 321.361)*

**69.03 ANGLE PARKING.** Angle or diagonal parking is permitted only in the following locations:

*(Code of Iowa, Sec. 321.361)*

1. North 44<sup>th</sup> Street, on the west side, from Cumming Avenue to North Alice Avenue.

**69.04 MANNER OF ANGLE PARKING.** Upon those streets or portions of streets that have been signed or marked for angle parking, no person shall park or stand a vehicle other than at an angle to the curb or edge of the roadway or in the center of the roadway as indicated by such signs and markings. No part of any vehicle or the load thereon, when said vehicle is parked within a diagonal parking district, shall extend into the roadway more than a distance of 16 feet when measured at right angles to the adjacent curb or edge of roadway.

*(Code of Iowa, Sec. 321.361)*

**69.05 PARKING FOR CERTAIN PURPOSES ILLEGAL.** No person shall park a vehicle upon public property for more than 36 hours, unless otherwise limited under the provisions of this chapter, or for any of the following principal purposes:

*(Code of Iowa, Sec. 321.236[1])*

1. Sale. Displaying such vehicle for sale.
2. Repairing. For lubricating, repairing or for commercial washing of such vehicle except such repairs as are necessitated by an emergency.
3. Advertising. Displaying advertising.
4. Merchandise Sales. Selling merchandise from such vehicle except in a duly established market place or when so authorized or licensed under this Code of Ordinances.

**69.06 PARKING PROHIBITED.** No one shall stop, stand, or park a vehicle except when necessary to avoid conflict with other traffic or in compliance with the directions of a peace officer or traffic control device, in any of the following places:

1. Crosswalk. On a crosswalk.  
*(Code of Iowa, Sec. 321.358[5])*
2. Center Parkway. On the center parkway or dividing area of any divided street.  
*(Code of Iowa, Sec. 321.236[1])*
3. Mailboxes. Within 20 feet on either side of a mailbox that is so placed and so equipped as to permit the depositing of mail from vehicles on the roadway.  
*(Code of Iowa, Sec. 321.236[1])*
4. Sidewalks. On or across a sidewalk.  
*(Code of Iowa, Sec. 321.358[1])*
5. Driveway. In front of a public or private driveway.  
*(Code of Iowa, Sec. 321.358[2])*
6. Intersection. Within an intersection or within 10 feet of an intersection of any street or alley.  
*(Code of Iowa, Sec. 321.358[3])*
7. Fire Hydrant. Within five feet of a fire hydrant.  
*(Code of Iowa, Sec. 321.358[4])*
8. Stop Sign or Signal. Within 10 feet upon the approach to any flashing beacon, stop or yield sign, or traffic control signal located at the side of a roadway.  
*(Code of Iowa, Sec. 321.358[6])*
9. Railroad Crossing. Within 50 feet of the nearest rail of a railroad crossing, except when parked parallel with such rail and not exhibiting a red light.  
*(Code of Iowa, Sec. 321.358[8])*
10. Fire Station. Within 20 feet of the driveway entrance to any fire station and on the side of a street opposite the entrance to any fire station within 75 feet of said entrance when properly sign posted.  
*(Code of Iowa, Sec. 321.358[9])*
11. Excavations. Alongside or opposite any street excavation or obstruction when such stopping, standing or parking would obstruct traffic.  
*(Code of Iowa, Sec. 321.358[10])*
12. Double Parking. On the roadway side of any vehicle stopped or parked at the edge or curb of a street.  
*(Code of Iowa, Sec. 321.358[11])*
13. Hazardous Locations. When, because of restricted visibility or when standing or parked vehicles would constitute a hazard to moving traffic, or when other traffic conditions require, the Council may cause curbs to be painted with a yellow color and erect no parking or standing signs.  
*(Code of Iowa, Sec. 321.358[13])*
14. Churches, Nursing Homes and Other Buildings. A space of 50 feet is hereby reserved at the side of the street in front of any theatre, auditorium, hotel having more than 25 sleeping rooms, hospital, nursing home, taxicab stand, bus depot, church, or other building where large assemblages of people are being held, within which space, when clearly marked as such, no motor vehicle shall

be left standing, parked or stopped except in taking on or discharging passengers or freight, and then only for such length of time as is necessary for such purpose.

*(Code of Iowa, Sec. 321.360)*

15. Alleys. No person shall park a vehicle within an alley in such a manner or under such conditions as to leave available less than 10 feet of the width of the roadway for the free movement of vehicular traffic, and no person shall stop, stand, or park a vehicle within an alley in such a position as to block the driveway entrance to any abutting property. The provisions of this subsection do not apply to a vehicle parked in any alley that is 18 feet wide or less, provided that said vehicle is parked to deliver goods or services.

*(Code of Iowa, Sec. 321.236[1])*

16. Ramps. In front of a curb cut or ramp which is located on public or private property in a manner which blocks access to the curb cut or ramp.

*(Code of Iowa, Sec. 321.358[15])*

17. In More Than One Space. In any designated parking space so that any part of the vehicle occupies more than one such space or protrudes beyond the markings designating such space.

**69.07 PERSONS WITH DISABILITIES PARKING.** The following regulations shall apply to the establishment and use of persons with disabilities parking spaces:

1. Establishment. Persons with disabilities parking spaces shall be established and designated in accordance with Chapter 321L of the *Code of Iowa* and Iowa Administrative Code, 661-18. No unauthorized person shall establish any on-street persons with disabilities parking space without first obtaining Council approval.

2. Improper Use. The following uses of a persons with disabilities parking space, located on either public or private property, constitute improper use of a persons with disabilities parking permit, which is a violation of this Code of Ordinances:

*(Code of Iowa, Sec. 321L.4[2])*

A. Use by an operator of a vehicle not displaying a persons with disabilities parking permit.

B. Use by an operator of a vehicle displaying a persons with disabilities parking permit but not being used by a person issued a permit or being transported in accordance with Section 321L.2[1b] of the *Code of Iowa*.

C. Use by a vehicle in violation of the rules adopted under Section 321L.8 of the *Code of Iowa*.

3. Wheelchair Parking Cones. No person shall use or interfere with a wheelchair parking cone in violation of the following:

A. A person issued a persons with disabilities parking permit must comply with the requirements of Section 321L.2A[1] of the *Code of Iowa* when utilizing a wheelchair parking cone.

B. A person shall not interfere with a wheelchair parking cone that is properly placed under the provisions of Section 321L.2A[1] of the *Code of Iowa*.

**69.08 NO PARKING ZONES.** No one shall stop, stand or park a vehicle in any of the following specifically designated no parking zones except when necessary to avoid conflict with other traffic or in compliance with the direction of a peace officer or traffic control signal.

*(Code of Iowa, Sec. 321.236[1])*

1. North 43<sup>rd</sup> Street, on the west side, from Cumming Avenue to Alice Avenue.
2. Alice Avenue, on the south side, from North 44<sup>th</sup> Street to North 43<sup>rd</sup> Street.
3. Alice Avenue, on the south side, from North 43<sup>rd</sup> Street to the east end of the street.
4. Birch Avenue, on the south side, from North 44<sup>th</sup> Street to North 43<sup>rd</sup> Street.
5. North 43<sup>rd</sup> Street, on the west side, from Birch Avenue to Callison Avenue.
6. Cumming Avenue, on the north side, from North 44<sup>th</sup> Street to North 43<sup>rd</sup> Street (from north side of sidewalk to center of roadway).
7. Cumming Avenue, on the south side, from North 44<sup>th</sup> Street to North 43<sup>rd</sup> Street (from existing fence line to center of roadway).

**69.09 TRUCK PARKING LIMITED.** No person shall park a semi-trailer, passenger bus used for commercial or school purposes, any vehicle in excess of five (5) tons, or other motor vehicle with trailer attached with total weight in excess of five (5) tons in violation of the following regulations.

*(Code of Iowa, Sec. 321.236[1])*

1. Streets. Excepting only when such vehicle are actually engaged in the delivery or receiving of merchandise or cargo, no person shall park or leave unattended such vehicle, on any street within the City except for designated parking areas on the City truck routes. When actually receiving or delivering merchandise or cargo such vehicle shall be stopped or parked in a manner which will not interfere with other traffic.
2. Noise. No such vehicle shall be left standing or parked upon any street, public or private parking lot, or drive of any service station between the hours of ten o'clock (10:00) p.m. and six o'clock (6:00) a.m. with the engine, auxiliary engine, air compressor, refrigerating equipment or other device in operation giving off audible sounds excepting only the drive of a service station when actually being serviced, and then in no event for more than thirty (30) minutes.
3. Livestock. No such vehicle containing livestock shall be parked on any street or highway for a period of time of more than thirty (30) minutes.

**69.10 SNOW REMOVAL.** No person shall park, abandon or leave unattended any vehicle on any public street, alley, or City-owned off-street parking area during snow removal operations unless the snow has been removed or plowed from said street, alley or parking area and the snow has ceased to fall.

*(Code of Iowa, 321.236[1])*

**69.11 SNOW ROUTES.** The Council may designate certain streets in the City as snow routes. When conditions of snow or ice exist on the traffic surface of a designated snow route, it is unlawful for the driver of a vehicle to impede or block traffic.

*(Code of Iowa, Sec. 321.236[12])*

**69.12 LOADING ZONES.** It is unlawful to park any vehicle in any areas designated and properly marked as a loading zone, except while expeditiously loading or unloading.

[The next page is 345]

# RESOLUTION 2020-49

## CITY OF CUMMING

### SET A PUBLIC HEARING DATE TO REZONE CERTAIN PROPERTY WITHIN THE CITY LIMITS OF CUMMING FROM A-1 AGRICULTURE DISTRICT TO C-1 HIGHWAY COMMERCIAL DISTRICT AND AMEND THE OFFICIAL ZONING MAP OF THE CITY OF CUMMING, IOWA

**WHEREAS**, The City Council of the City of Cumming, Iowa, desires to consider changing the zoning on certain properties within the city limits of the City of Cumming, Iowa, from A-1 Agriculture District to C-1 Highway Commercial District, and

**WHEREAS**, The property is described as follows:

A PART OF THE SOUTHWEST QUARTER OF THE SOUTHEAST QUARTER AND A PART OF THE SOUTHEAST QUARTER OF THE SOUTHEAST QUARTER, ALL IN SECTION 7, TOWNSHIP 77 NORTH, RANGE 25 WEST OF THE FIFTH PRINCIPAL MERIDIAN IN THE CITY OF CUMMING, WARREN COUNTY, IOWA AND MORE PARTICULARLY DESCRIBED AS FOLLOWS:

COMMENCING AT THE SOUTH QUARTER CORNER OF SAID SECTION 7; THENCE NORTH 89°28'07" EAST ALONG THE SOUTH LINE OF SAID SOUTHWEST QUARTER OF THE SOUTHEAST QUARTER, 915.66 FEET TO THE SOUTHWEST CORNER OF TRACT 'A' AS SHOWN ON THE IOWA DEPARTMENT OF TRANSPORTATION ACQUISITION PLAT RECORDED IN BOOK 2012, PAGE 5962; THENCE NORTH 00°15'20" EAST ALONG THE WEST LINE OF SAID TRACT 'A', 40.00 FEET; THENCE NORTH 46°06'53" WEST CONTINUING ALONG SAID WEST LINE, 59.17 FEET TO THE POINT OF BEGINNING; THENCE NORTH 45°54'18" WEST, 76.74 FEET; THENCE NORTH 30°10'37" EAST, 224.05 FEET; THENCE NORTH 89°28'07" EAST, 480.83 FEET; THENCE SOUTH 00°31'53" EAST, 327.95 FEET TO THE SOUTH LINE OF SAID SOUTHEAST QUARTER; THENCE SOUTH 89°28'07" WEST ALONG SAID SOUTH LINE, 70.00 FEET; THENCE NORTH 00°31'53" WEST, 40.00 FEET TO THE NORTHERLY RIGHT OF WAY LINE OF HIGHWAY G14/CUMMING AVENUE; THENCE SOUTH 89°28'07" WEST ALONG SAID NORTHERLY RIGHT OF WAY LINE, 175.70 FEET; THENCE NORTH 82°32'22" WEST CONTINUING ALONG SAID NORTHERLY RIGHT OF WAY LINE, 297.82 FEET TO THE POINT OF BEGINNING AND CONTAINING 3.52 ACRES (153,340 SQUARE FEET).

THE PROPERTY IS SUBJECT TO ANY AND ALL EASEMENTS OF RECORD.

**WHEREAS**, Iowa Law requires a Public Hearing be held before the Council prior to any changes in zoning district boundaries,

**NOW, THEREFORE, BE IT RESOLVED**, by the City Council of the City of Cumming, Iowa, as follows:

Section 1. The Council will meet at City Hall, 649 N. 44<sup>th</sup> Street, Cumming, Iowa, on the 14<sup>th</sup> day of September, 2020, at 7:00 p.m., at which time and place it will hold a public hearing on the matter of amending a district boundary on property as described above, from A-1 Agriculture District to C-1 Highway Commercial District.

Section 2. The City Clerk shall post notice of said hearing, which posting shall be at the three public places in said City which have been permanently designated by ordinance, and such posting shall be at least 7 days but not more than 20 days prior to any action by the City Council.

Passed and approved this 10<sup>th</sup> day of August, 2020.

\_\_\_\_\_  
Tom Becker, Mayor

Attest:

\_\_\_\_\_  
Angie Ritchie, Deputy Clerk

# NOTICE OF PUBLIC HEARING CITY OF CUMMING

## TO AMEND THE OFFICIAL ZONING MAP OF THE CITY OF CUMMING, IOWA BY REZONING CERTAIN PROPERTY WITHIN THE CITY LIMITS

Notice is hereby given that the City Council of the City of Cumming, Iowa, will conduct a public hearing on Monday, September 14, 2020, 7:00 P.M. at the Cumming City Hall, 649 N. 44<sup>th</sup> Street, Cumming, Iowa, to receive comments on the following:

Amend the official zoning map of the City of Cumming, Iowa, by rezoning certain property within the city limits from A-1 Agriculture District to C-1 Highway Commercial District described as follows:

A PART OF THE SOUTHWEST QUARTER OF THE SOUTHEAST QUARTER AND A PART OF THE SOUTHEAST QUARTER OF THE SOUTHEAST QUARTER, ALL IN SECTION 7, TOWNSHIP 77 NORTH, RANGE 25 WEST OF THE FIFTH PRINCIPAL MERIDIAN IN THE CITY OF CUMMING, WARREN COUNTY, IOWA AND MORE PARTICULARLY DESCRIBED AS FOLLOWS:

COMMENCING AT THE SOUTH QUARTER CORNER OF SAID SECTION 7; THENCE NORTH 89°28'07" EAST ALONG THE SOUTH LINE OF SAID SOUTHWEST QUARTER OF THE SOUTHEAST QUARTER, 915.66 FEET TO THE SOUTHWEST CORNER OF TRACT 'A' AS SHOWN ON THE IOWA DEPARTMENT OF TRANSPORTATION ACQUISITION PLAT RECORDED IN BOOK 2012, PAGE 5962; THENCE NORTH 00°15'20" EAST ALONG THE WEST LINE OF SAID TRACT 'A', 40.00 FEET; THENCE NORTH 46°06'53" WEST CONTINUING ALONG SAID WEST LINE, 59.17 FEET TO THE POINT OF BEGINNING; THENCE NORTH 45°54'18" WEST, 76.74 FEET; THENCE NORTH 30°10'37" EAST, 224.05 FEET; THENCE NORTH 89°28'07" EAST, 480.83 FEET; THENCE SOUTH 00°31'53" EAST, 327.95 FEET TO THE SOUTH LINE OF SAID SOUTHEAST QUARTER; THENCE SOUTH 89°28'07" WEST ALONG SAID SOUTH LINE, 70.00 FEET; THENCE NORTH 00°31'53" WEST, 40.00 FEET TO THE NORTHERLY RIGHT OF WAY LINE OF HIGHWAY G14/CUMMING AVENUE; THENCE SOUTH 89°28'07" WEST ALONG SAID NORTHERLY RIGHT OF WAY LINE, 175.70 FEET; THENCE NORTH 82°32'22" WEST CONTINUING ALONG SAID NORTHERLY RIGHT OF WAY LINE, 297.82 FEET TO THE POINT OF BEGINNING AND CONTAINING 3.52 ACRES (153,340 SQUARE FEET).

THE PROPERTY IS SUBJECT TO ANY AND ALL EASEMENTS OF RECORD.

Additional information regarding this request may be obtained by contacting the Deputy Clerk at 981-9214.

Anyone wishing to comment on this request should attend this hearing or submit written comments at any time prior to the hearing. Send comments to City of Cumming, P.O. Box 100, Cumming, IA. 50061.



FILE: H:\2020\2002258\2002258-REZONING\DWG  
 DATE: 8/6/2020 11:43 AM  
 PLOT: 11:43 AM  
 USER: KJG  
 PLOT: 11:43 AM

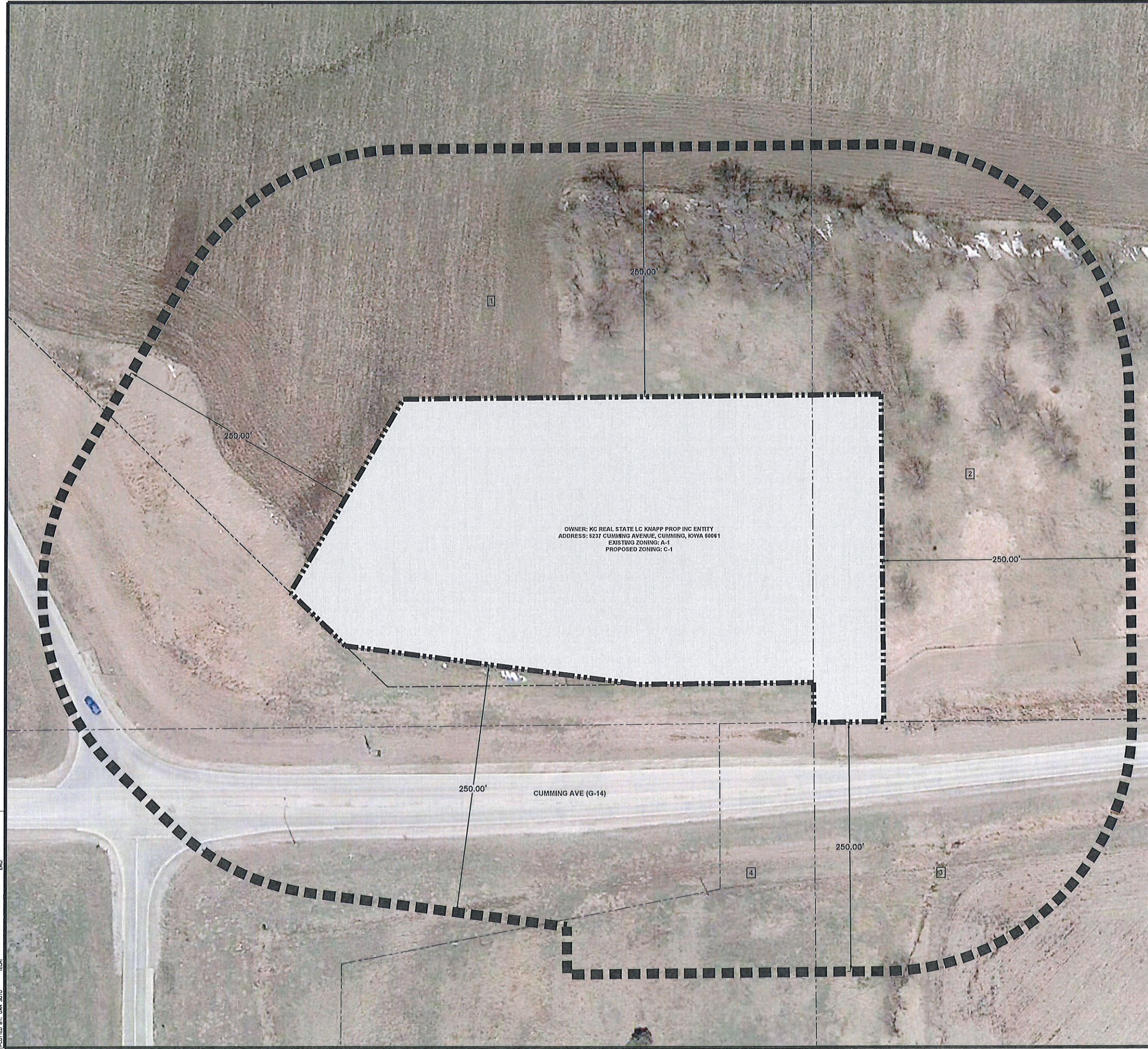

**PETITION FOR CHANGE IN ZONING CLASSIFICATION**

	Name of Property Owner	Mailing Address	Total Area of Property (SF)	Area within 250' of Rezoning (SF)	% of Total SF within 250' of Rezoning
1	Kc Real State Lc Knapp Prop Inc Entity	5000 West Town Pkwy, Ste 400 West Des Moines,	963,547	183,568	42.01%
2	Kc Real State Lc Knapp Prop Inc Entity	5000 West Town Pkwy, Ste 400 West Des Moines,	1,646,568	148,321	33.94%
3	Middletown Family LC	3930 Grand Ave #308 Des Moines, IA 50312	1,578,614	66,587	15.24%
4	Middletown Family LC	3930 Grand Ave #308 Des Moines, IA 50312	5,011,578	38,511	8.81%
	<b>TOTAL</b>		<b>9,200,307</b>	<b>436,987</b>	<b>100.00%</b>

**ZONING**  
 EXISTING: A-1 (AGRICULTURE DISTRICT)  
 PROPOSED: C-1 (HIGHWAY COMMERCIAL DISTRICT)

**REZONING BOUNDARY DESCRIPTION**  
 A PART OF THE SOUTHWEST QUARTER OF THE SOUTHWEST QUARTER AND A PART OF THE SOUTHWEST QUARTER OF THE SOUTHWEST QUARTER, ALL IN SECTION 7, TOWNSHIP 77 NORTH, RANGE 25 WEST OF THE FIFTH PRINCIPAL MERIDIAN IN THE CITY OF CUMMING, WARREN COUNTY, IOWA AND MORE PARTICULARLY DESCRIBED AS FOLLOWS: COMMENCING AT THE SOUTH QUARTER CORNER OF SAID SECTION 7; THENCE NORTH 89°28'07" EAST ALONG THE SOUTH LINE OF SAID SOUTHWEST QUARTER OF THE SOUTHWEST QUARTER, 915.66 FEET TO THE SOUTHWEST CORNER OF TRACT 'A' AS SHOWN ON THE IOWA DEPARTMENT OF TRANSPORTATION ACQUISITION PLAT RECORDED IN BOOK 2012, PAGE 5962; THENCE NORTH 00°15'20" EAST ALONG THE WEST LINE OF SAID TRACT 'A', 40.00 FEET; THENCE NORTH 46°06'53" WEST CONTINUING ALONG SAID WEST LINE, 59.17 FEET TO THE POINT OF BEGINNING; THENCE NORTH 45°54'18" WEST, 76.74 FEET; THENCE NORTH 30°10'37" EAST, 224.05 FEET; THENCE NORTH 89°28'07" EAST, 480.83 FEET; THENCE SOUTH 00°31'53" EAST, 327.95 FEET TO THE SOUTH LINE OF SAID SOUTHWEST QUARTER; THENCE SOUTH 89°28'07" WEST ALONG SAID SOUTH LINE, 70.00 FEET; THENCE NORTH 00°31'53" WEST, 40.00 FEET TO THE NORTHERLY RIGHT OF WAY LINE OF HIGHWAY G14/CUMMING AVENUE; THENCE SOUTH 89°28'07" WEST ALONG SAID NORTHERLY RIGHT OF WAY LINE, 175.70 FEET; THENCE NORTH 82°32'22" WEST CONTINUING ALONG SAID NORTHERLY RIGHT OF WAY LINE, 297.82 FEET TO THE POINT OF BEGINNING AND CONTAINING 3.52 ACRES (153,340 SQUARE FEET). THE PROPERTY IS SUBJECT TO ANY AND ALL EASEMENTS OF RECORD.

**OWNER**  
 KC REAL STATE LC KNAPP PROP INC ENTITY  
 5000 WEST TOWN PKWY, STE 400  
 WEST DES MOINES, IA 50266

**OWNER**  
 KUM & GO LC  
 CONTACT: BRITNI ANDREASSEN  
 1459 GRAND AVE.  
 DES MOINES, IA 50309  
 PH. (515) 457-6083

**APPLICANT**  
 KUM & GO LC  
 CONTACT: BRITNI ANDREASSEN  
 1459 GRAND AVE.  
 DES MOINES, IA 50309  
 PH. (515) 457-6083

**ENGINEER**  
 CIVIL DESIGN ADVANTAGE, LLC  
 CONTACT: KEITH WEGGEN  
 3405 SE CROSSROADS DRIVE, SUITE G  
 GRIMES, IOWA 50111  
 PH. (515) 369-4400  
 FX. (515) 369-4410



1456 GRAND AVENUE  
 Des Moines, Iowa 50309  
 P: 515-226-0128  
 F: 515-223-9873

0198 - CUMMING, IOWA  
 I-35 & CUMMING AVENUE  
 REZONING EXHIBIT

KG PROJECT TEAM:  
 RDR:  
 SDM:  
 CPM:

DATE	REVISION DESCRIPTION

DATE: 08-06-2020

SHEET NUMBER:

1 OF 1

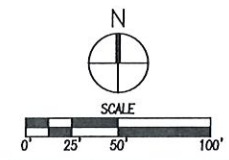

**RESOLUTION NO. 2020-52**

Resolution Setting Date for Public Hearing on Urban Renewal Plan Amendment

WHEREAS, the City Council of the City of Cumming, Iowa (the “City”) by resolution previously established the Consolidated Cumming Urban Renewal Areas (the “Urban Renewal Areas”) and adopted an urban renewal plan (the “Plan”) for the governance of initiatives and projects therein; and

WHEREAS, an amendment (the “Amendment”) to the Plan has been prepared which authorizes the undertaking of new urban renewal projects in the Urban Renewal Areas consisting of (1) providing tax increment financing support to Diligent GWC, LLC, in connection with the construction of public infrastructure necessary for the development of a residential subdivision, including the construction of a park and recreational trails; and (2) using tax increment financing to pay the costs of undertaking the City’s South Sewer Extension Project in support of commercial development in the Urban Renewal Area; and it is now necessary that a date be set for a public hearing on the Amendment;

NOW, THEREFORE, Be It Resolved by the City Council of the City of Cumming, Iowa, as follows:

Section 1. This City Council will meet electronically or at the City Hall, Cumming, Iowa, on September 14, 2020, at 7 o’clock p.m., at which time and place it will hold a public hearing on the proposed Amendment.

Section 2. The City Clerk shall publish notice of said hearing, the same being in the applicable form attached hereto, which publication shall be made in a legal newspaper of general circulation in the City, which publication shall be not less than four (4) and not more than twenty (20) days before the date set for hearing.

Section 3. Pursuant to Section 403.5 of the Code of Iowa, the City Clerk is hereby designated as the City’s representative in connection with the consultation process which is required under that section of the urban renewal law.

Passed and approved this August 10, 2020.

\_\_\_\_\_  
Tom Becker, Mayor

Attest:

\_\_\_\_\_  
Angie Ritchie, Deputy Clerk

## NOTICE OF ELECTRONIC HEARING

### NOTICE OF PUBLIC HEARING ON PROPOSED URBAN RENEWAL PLAN AMENDMENT

Notice Is Hereby Given: That at 7 o'clock p.m., at the City Hall, Cumming, Iowa, on September 14, 2020, the City Council of the City of Cumming, Iowa, will hold a public hearing on the question of amending the urban renewal plan for the Consolidated Cumming Urban Renewal Areas (the "Urban Renewal Areas") to authorize the undertaking of new urban renewal projects in the Urban Renewal Areas consisting of (1) providing tax increment financing support to Diligent GWC, LLC, in connection with the construction of public infrastructure necessary for the development of a residential subdivision, including the construction of a park and recreational trails; and (2) using tax increment financing to pay the costs of undertaking the City's South Sewer Extension Project in support of commercial development in the Urban Renewal Area. A copy of the amendment is on file for public inspection in the office of the City Clerk.

Due to federal and state government recommendations in response to COVID-19 pandemic conditions, the meeting will be held electronically via Zoom, which will be accessible at the following:

<https://us02web.zoom.us/j/87981005255?pwd=Q21vQkFHVlNpUDJlVlc2QktPNmNndz09>

In addition to electronic access, written comments may be filed or made prior to the meeting and will be recorded in the minutes.

At said hearing any interested person may file written objections or comments and may be heard orally with respect to the subject matters of the hearing.

Angie Ritchie  
Deputy Clerk

**NOTICE OF IN-PERSON HEARING**

**NOTICE OF PUBLIC HEARING ON PROPOSED  
URBAN RENEWAL PLAN AMENDMENT**

Notice Is Hereby Given: That at 7 o'clock p.m., at the City Hall, 649 N. 44<sup>th</sup> St., Cumming, Iowa, on September 14, 2020, the City Council of the City of Cumming, Iowa, will hold a public hearing on the question of amending the urban renewal plan for the Consolidated Cumming Urban Renewal Areas (the "Urban Renewal Areas") to authorize the undertaking of new urban renewal projects in the Urban Renewal Areas consisting of (1) providing tax increment financing support to Diligent GWC, LLC, in connection with the development of a residential community, including the construction of a park and recreational trails; and (2) using tax increment financing to pay the costs of undertaking the City's South Sewer Extension Project in support of commercial development in the Urban Renewal Area. A copy of the amendment is on file for public inspection in the office of the City Clerk.

At said hearing any interested person may file written objections or comments and may be heard orally with respect to the subject matters of the hearing.

Angie Ritchie  
Deputy Clerk

**Resolution 2020-53**  
**City of Cumming**

**Resolution Approving Plat of Survey Parcel "F" in Warren County, Iowa**

**WHEREAS**, there was filed in the Office of the City Clerk of the City of Cumming, Warren County, Iowa, a registered land surveyor's plat of survey known as Parcel "F"; and

**WHEREAS**, the real estate comprising said plat is described as follows:

**Parcel 'F'**, That part of Lot 9 of Bellevue Subdivision, recorded in Plat Book 5 Page 60 of Section 20, Township 77 North, Range 25 West of the 5<sup>th</sup> P.M., Warren County, Iowa, described as follows;

Beginning at the Southeast corner of said Lot 9; thence North 00 degrees 29 minutes 27 seconds West, 886.99 feet along the East line of said Lot 9; thence South 66 degrees 32 minutes 30 seconds West, 338.32 feet to the West line of said Lot 9; thence South 00 degrees 33 minutes 08 seconds East, 752.94 feet along said West line to the Southwest corner of said Lot 9; thence North 89 degrees 53 minutes 05 seconds East, 310.70 feet to the Point of Beginning, having an area of 5.86 Acres.

**WHEREAS**, the City Council of the City of Cumming, Warren County, Iowa, finds that said plat conforms to the provisions of the Ordinances of the City of Cumming, Warren County, Iowa, and that the plat, papers and documents presented therewith should be approved by the City Council of the City of Cumming, Warren County, Iowa.

**NOW, THEREFORE, BE IT RESOLVED** by the City Council of the City of Cumming, Warren County, Iowa:

1. Said Plat, known as Parcel "F" prepared in connection with said plat is hereby approved on condition of receipt of signed pre-annexation documents with the City of Cumming.

2. The City of Cumming, Warren County, Iowa, is hereby directed to certify this resolution which shall be affixed to said plat to the County documents which should be filed and recorded in connection therewith.

Passed and Approved, this 10<sup>th</sup> day of August, 2020.

\_\_\_\_\_  
Tom Becker, Mayor

Attest:

\_\_\_\_\_  
Angie Ritchie, Deputy Clerk

PLAT OF SURVEY

SURVEY LEGEND

INDEX LEGEND

LOCATION: LOT 9, BELLEVUE SUBDIVISION  
NW 1/4 OF SECTION 20, T 77N, R 25W, WARREN COUNTY, IOWA

OWNER: MATTHEW J ROTH  
2244 COOLIDGE ST., NORWALK IA 50211

SURVEY FOR: (OWNER)

PREPARED BY CHAD A. DANIELS  
DANIELS LAND SURVEYING, 22598 18TH AVE, NEW VIRGINIA IA 50210  
RETURN TO: 515-577-2583

- ( ) - Recorded Distance/Bearing
- --- --- Road Easement
- . - . - . Section line
- \* - \* - Fence line

Monuments

- ▲ - Found section corner
- - Set 1/2" red plastic capped rebar, #17532
- - Found pipe

BASIS OF BEARINGS IS IA RCS ZONE 8

DESCRIPTION - PARCEL F:

That part of Lot 9 of Bellevue Subdivision, recorded in Plat Book 5 Page 60 of Section 20, Township 77 North, Range 25 West of the 5th P.M., Warren County, Iowa, described as follows;

Beginning at the Southeast corner of said Lot 9; thence North 00 degrees 29 minutes 27 seconds West, 886.99 feet along the East line of said Lot 9; thence South 66 degrees 32 minutes 30 seconds West, 338.32 feet to the West line of said Lot 9; thence South 00 degrees 33 minutes 08 seconds East, 752.94 feet along said West line to the Southwest corner of said Lot 9; thence North 89 degrees 53 minutes 05 seconds East, 310.70 feet to the Point of Beginning, having an area of 5.86 Acres.

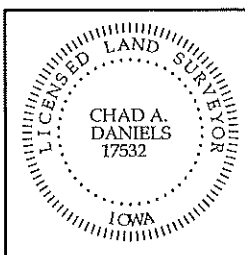

I hereby certify that this surveying document was prepared by me and the related survey work was performed by me or under my direct personal supervision and that I am a duly licensed Land Surveyor under the laws of the State of Iowa.

Signed Chad A. Daniels Date 7/20/20  
Chad A. Daniels Date

Iowa License No. 17532  
My license renewal date is 12-31-2020  
Page No.'s covered by this seal: 1 and 2

0 150 300 FEET

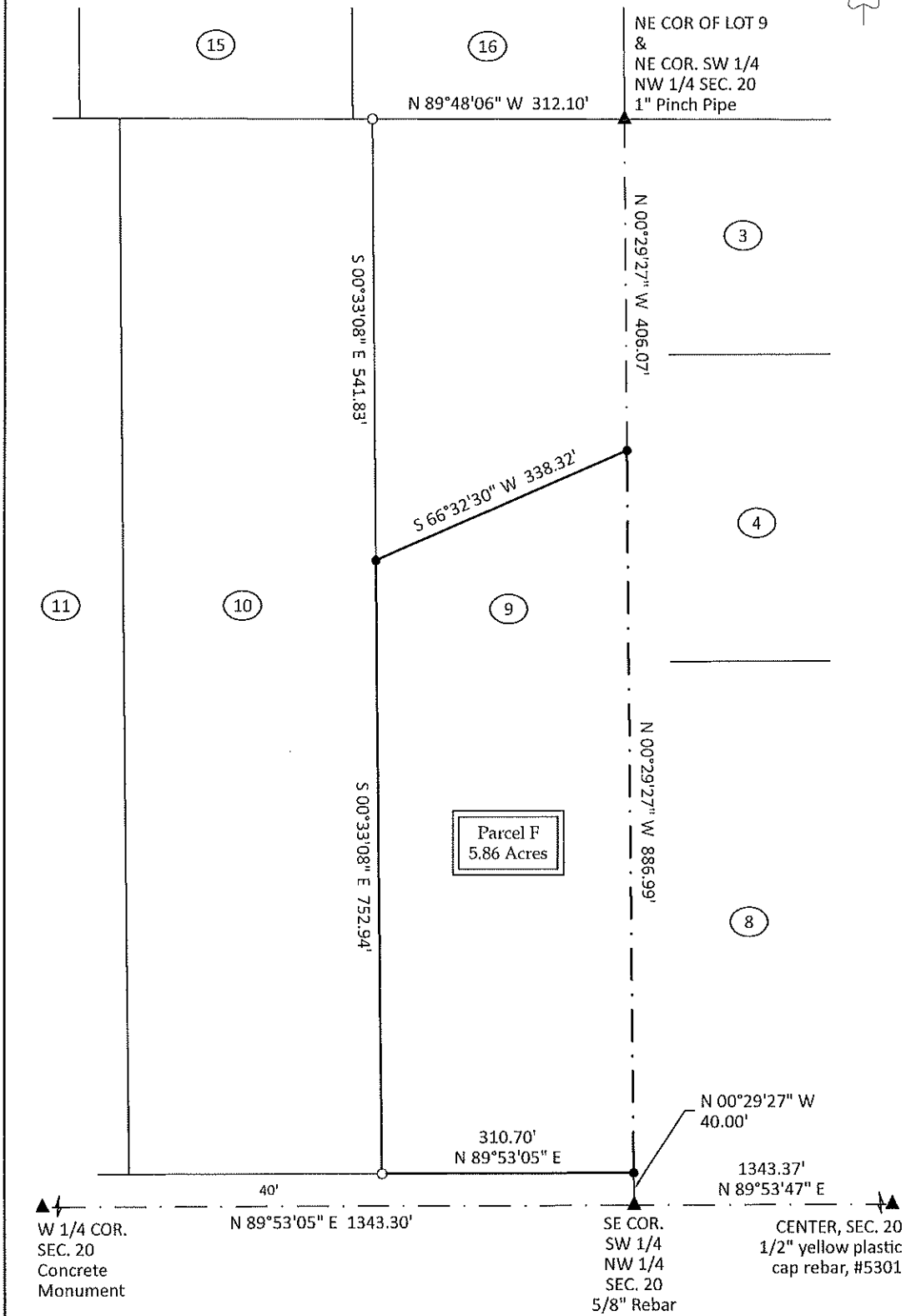
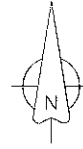

## PRE-ANNEXATION AGREEMENT

This Pre-Annexation Agreement (hereinafter referred to as (“Agreement”) is entered into by and between the City of Cumming, Iowa, a municipal corporation (hereinafter referred to as the “City”) and by Matthew J. Roth, a single person (hereinafter referred to as “Owner”), being the owner of the following described real estate to wit:

Lot 9 in Bellevue, an Official Plat, now included in and forming a part of Linn Township, Warren County, Iowa, subject to the protective covenants of record in the Office of the Warren County Recorder

(hereinafter referred to as “Subject Property”).

### WITNESSETH:

WHEREAS, the Subject Property is presently located entirely within Warren County, Iowa, and outside the corporate limits of any other city; and,

WHEREAS, the Owner has requested approval for a Plat of Survey from the City of Cumming, Iowa, and the City of Cumming, Iowa, has consented to approval of said Plat of Survey;

WHEREAS, Owner is making application for voluntary annexation into the City of Cumming, Iowa this date. Said application for voluntary annexation to be acted upon under the terms and conditions as set out herein; and,

NOW THEREFORE, in consideration of the mutual promises contained herein, and other good and valuable consideration, it is agreed between City and Owner, as follows:

1. **Plat of Survey.** The City of Cumming approves the Plat of Survey submitted by Owner.
2. **Irrevocable.** This Pre-Annexation Agreement shall become irrevocable upon execution by the Owner.
3. **Severability.** If any provisions, conditions, or covenants of this Agreement, or the application thereof to any circumstances of either Party, shall be held invalid or unenforceable, the remainder of this Agreement or the application of such provision, condition, or covenant to persons or circumstances other than those as to whom or which it is held invalid or unenforceable shall not be affected thereby and shall be valid and enforceable to the fullest extent permitted by law.



The City of Cumming agrees to annex the property at a time of the City's choosing.

Dated this \_\_\_\_\_ day of \_\_\_\_\_ 2020.

OWNER(S)

\_\_\_\_\_  
Matthew J. Roth

CITY OF CUMMING, IOWA

\_\_\_\_\_  
Mayor, Tom Becker

\_\_\_\_\_  
Deputy City Clerk, Angie Ritchie

# VOLUNTARY PETITION OF ANNEXATION TO THE CITY OF CUMMING, IOWA

Know all men by these presents that whereas Matthew J. Roth, a single person, is the owner of the following described real estate to wit:

Lot 9 in Bellevue, an Official Plat, now included in and forming a part of Linn Township, Warren County, Iowa, subject to the protective covenants of record in the Office of the Warren County Recorder

That this Voluntary Petition of Annexation is hereby presented to the City Council of the City of Cumming, Iowa and to the City Development Board exercising our independent right to request voluntary annexation of the subject real estate into the City of Cumming, Iowa this \_\_\_\_\_ day of \_\_\_\_\_ 2020.

That this Voluntary Petition of Annexation to the City of Cumming, Iowa shall be binding upon the Owner, their heirs, transferees, successors in interest, and/or assigns, and may only be revoked according to the terms of the Pre-Annexation Agreement if said terms, conditions, and provisions are not complied with by the City Council of the City of Cumming, Iowa. That this Voluntary Petition shall run with the land and is subject to the Restrictive Covenant and Development Agreement executed concurrently herewith.

OWNER(S):

\_\_\_\_\_  
Matthew J. Roth

**RESTRICTIVE COVENANT AND DEVELOPMENT AGREEMENT**

STATE OF IOWA                    )  
  ) ss.  
COUNTY OF WARREN         )

COMES NOW Matthew J. Roth, a single person (hereinafter “Owner”), of the following described real estate:

Lot 9 in Bellevue, an Official Plat, now included in and forming a part of Linn Township, Warren County, Iowa, subject to the protective covenants of record in the Office of the Warren County Recorder

And does hereby make the following Agreement with the City of Cumming, Iowa:

WHEREAS the City of Cumming, Iowa has consented to Owner connecting to the City’s sewer system.

NOW THEREFORE in consideration of that consent, the owner as aforementioned and the heirs, successors in interest, transferees, and/or assigns of the above described real estate, agree that said real estate is subject to an Application for Voluntary Annexation into the City of Cumming, Iowa. That said Application for Voluntary Annexation to the City of Cumming, Iowa, is on file with the City of Cumming, Iowa and is to be used by the City of Cumming, Iowa as soon as it is practical to do so. Further, that this real estate shall eventually become a part of the City of Cumming, Iowa.

That this covenant shall run with the land and be a restriction thereon subject to the contents thereof.

That adequate consideration has been given for such restriction.

Dated this \_\_\_\_ day of \_\_\_\_\_, 2020.

OWNER(S)

\_\_\_\_\_  
Matthew J. Roth

Subscribed and sworn to before me, a Notary Public, on this the \_\_\_\_ day of \_\_\_\_\_, 2020, by the said Matthew J. Roth, a single person, to me personally known.

\_\_\_\_\_  
Notary Public In and for the State of Iowa

## APPLICATION FOR VOLUNTARY ANNEXATION

To: Mayor and Cumming City Council, City Hall, 649 N 44<sup>th</sup> Street,  
Cumming, Iowa 50061.

Subject: Annexation – Property owned by Matthew J. Roth

Honorable Mayor and Members of the City Council:

Re: The property identified in Exhibit A is owned by the owner namely,  
Matthew J. Roth, a single person (hereinafter “Owner”)

Owner states as follows:

1. Owner is the owner of the property identified in Exhibit A (exclusive of public rights-of-way). Owner requests that the property identified in Exhibit A (hereinafter referred to as “Subject Property”) be voluntarily annexed into the City of Cumming, Iowa (hereinafter referred to as “City”).
2. Owner hereby makes application to City to voluntarily annex the Subject Property subject to certain terms, conditions and provisions of a Pre-Annexation Agreement (hereinafter referred to as “Agreement”) to which this Application is attached.

All of the terms, conditions and provisions of the Pre-Annexation Agreement shall by this reference be incorporated and made a part of this Application for Voluntary Annexation if as set forth verbatim herein.

3. This Application for Annexation shall be binding upon the Owner, their heirs, successors in interest and/or assigns, if any, and may only be revoked according to the terms of the Pre-annexation Agreement if said terms, conditions and provisions are not complied with by the City Council of the City of Cumming, Iowa.

Dated this \_\_\_\_\_ day of \_\_\_\_\_ 2020.

OWNER(S):

---

Matthew J. Roth

## EXHIBIT A

Lot 9 in Bellevue, an Official Plat, now included in and forming a part of Linn Township, Warren County, Iowa, subject to the protective covenants of record in the Office of the Warren County Recorder

**RESOLUTION 2020-54**  
**City of Cumming**

**A Resolution of the City of Cumming Relating to  
Employment of the City Administrator Applicable to Employees  
Not Within the Civil Service**

**WHEREAS**, The City Council, City of Cumming, Warren County, Iowa, has the authority to appoint and remove department heads, officers, and employees of the City, and

**WHEREAS**, The City of Cumming, Iowa, is in need of the specialized administrative knowledge of \_\_\_\_\_, and

**WHEREAS**, The City Council, City of Cumming, Iowa, has the authority to determine the powers and duties of each department or office, and to fix compensation of appointive officers and employees, is vested in the City Council, and

**WHEREAS**, in so appointing the City Administrator, the City Council finds that the employment of \_\_\_\_\_ is in the best interests of the City,

**THEREFORE, BE IT RESOLVED**, that the Mayor is hereby authorized and directed to execute said resolution for the employment of \_\_\_\_\_ as City Administrator, for and on behalf of the City of Cumming, Iowa.

Passed and approved this 10<sup>th</sup> day of August, 2020.

\_\_\_\_\_  
Tom Becker, Mayor

Attest: \_\_\_\_\_  
Angie Ritchie, Deputy Clerk

**Resolution 2020-55  
City of Cumming**

**Resolution Approving Employment Contract Agreement**

**WHEREAS**, the City Council of the City of Cumming, Iowa, approved by vote at the Regular City Council meeting on August 10, 2020, to hire \_\_\_\_\_ as City Administrator for the City of Cumming; and

**WHEREAS**, the City Council of the City of Cumming, Iowa, hereby approves the attached Employment Contract and Agreement between \_\_\_\_\_ and the City of Cumming, Iowa; and

**NOW, THEREFORE BE IT RESOLVED** by the City Council of the City of Cumming, Iowa:

Section 1. That the City of Cumming, Iowa, approves the Employment Contract and Agreement attached hereto.

Section 2. That the Mayor of the City of Cumming, Iowa, is hereby directed to sign the attached Employment Contract Agreement.

**Passed and approved this 10th day of August, 2020.**

\_\_\_\_\_  
Tom Becker, Mayor

Attest: \_\_\_\_\_  
Angie Ritchie, Deputy Clerk



# City of Cumming Employment Contract and Agreement

**THIS EMPLOYMENT CONTRACT AND AGREEMENT** made and entered into on \_\_\_\_\_, 2020 by and between the City of Cumming, Iowa, by its Council Members (hereinafter referred to as “Employer”) and \_\_\_\_\_, an individual and resident of the State of Iowa (hereinafter referred to as “Employee”) both whom understand as follows:

**WHEREAS**, the Employer desires to retain the services of the Employee as City Administrator effective \_\_\_\_\_, 2020; and

**WHEREAS**, it is the desire of the Employer to (1) offer inducement to Employee in an effort to secure his/her employment and to induce her/him to remain in such employment in the future; (2) to establish the job duties and responsibilities of said Employee; and (3) to provide means for terminating Employee’s services when either the Employee or the Employer may desire to terminate the Employer-Employee relationship; and

**WHEREAS**, the Employee desires to retain employment as City Administrator of Cumming, Iowa.

**NOW THEREFORE, THE PARTIES AGREE AS FOLLOWS:**

- (1) The Employee understands that he will serve as City Administrator of the City of Cumming, Iowa. Nothing in this Agreement shall prevent, limit, or otherwise interfere with the right of the Council to determine that Employee shall no longer serve as City Administrator, subject only to the provisions set forth in this Contract.
- (2) Nothing shall prevent, limit or otherwise interfere with the right of the Employee to resign at any time from his position with Employer; subject only to the provisions set forth in this Contract.
- (3) In the event Employee voluntarily resigns his position with Employer during a contract term, the Employee shall give the Employer sixty (60) days’ notice in advance, unless the parties otherwise agree. The Employee shall not be entitled to severance benefits of any kind, except he shall receive payment for unused vacation and other benefits usually paid to other Employees at termination provided the required notice is given.
- (4) The Employer may terminate this contract at any time for just cause and, if the Employee is terminated for just cause, he shall receive no severance pay, except he shall receive payment for unused vacation and other benefits usually paid to other Employees at termination. In the event the Employer wishes to terminate the contract without just cause, it may do so by giving the Employee thirty (30) days’ notice, in writing. In such event, the Employee, if requested by the Employer, shall continue to render his services and shall be paid his regular compensation up to the date of termination.
  - (a) **JUST CAUSE DEFINED.** Just cause shall include but not be limited to professional incompetence and other faults attributable to the employee, but shall not include legitimate reasons relating to the City’s personnel and budgetary requirements.

- (5) The Employer shall furnish the Employee all equipment, material and manpower necessary for the efficient performance of the official duties as City Administrator.
- (6) The Employee shall perform those duties outlined in the ordinance, Chapter 21 entitled "City Administrator" and such additional duties as may be assigned by the City Council.
- (7) That the Employee shall devote his full time and talents to the best of his ability to advance the best interests of the City of Cumming, Iowa.
- (8) Employer agrees to pay Employee for his services rendered, at an annual base salary of \_\_\_\_\_ (\$\_\_\_\_\_), effective \_\_\_\_\_, 2020, for the contract term payable in equal installments at the same time as other employees of the Employer are paid. The Employer shall not, at any time during the term of this Agreement, reduce the salary or other benefits of the Employee. The employee's salary may be increased periodically as approved by the City Council by resolution without amendment to this agreement.
- (9) It is understood that the Employee will normally work at least \_\_\_\_\_ (\_\_\_) hours per week, exclusive of scheduled Council Meetings and other evening meetings where his presence is required. It is also recognized that the Employee must devote a substantial amount of time outside the normal office hours to the business of the Employer, and to that end Employee may vary his schedule accordingly.
- (10) Employer shall defend, hold harmless and indemnify Employee against any tort or liability claim or demand or any other legal action arising from City activities or any alleged act or omission occurring in the performance of Employee's duties as City Manager; provided said acts are not in violation of any state or federal criminal statutes.
  - A. **VACATION.** The Employee shall accrue vacation at the rate of \_\_\_\_\_ weeks (\_\_\_\_\_ hours) of paid vacation per annum.
  - B. **HOLIDAYS.** Employee is considered to be on-call twenty-four (24) hours a day; however, unless his services are needed, the Employee shall not be required to work on those days which have been designated as holidays in the City's Personnel Policy/Handbook.
  - C. **PROFESSIONAL DUES AND SUBSCRIPTIONS.** Employer shall budget and pay for professional dues and subscriptions necessary for Employee's memberships in various associations and organizations which are necessary and desirable for his continued professional participation and growth for the good of the Employer, and to pay for any professional development or training expenses that have been previously approved by the City Council. The employer shall budget funds for membership and meeting attendance including but not limited to International City/County Management Association (ICMA), American Planning Association (APA), and the state and local city management associations. Those publications deemed to be necessary and desirable shall include, but not limited to, regular publications of the above organizations. Those meetings and seminars deemed to be necessary and desirable shall include, but not limited to, ICMA Annual Conference, APA Annual Conference, the Iowa League of Cities and the state and local city management associations.

**D. HEALTH INSURANCE.** The Employer will offer and provide Employee with the same insurance benefits available to other City Employees.

**E. OTHER LEAVES AND BENEFITS.** The Employer will provide other leaves of absence and benefits available to other City Employees as designated in the City's Personnel Policy/Handbook.

**F. RESIDENCY REQUIREMENT.** The City Council of the City of Cumming, Iowa, by approval of this Employment Contract and Agreement, hereby waives the Residency Requirement in section 21.05 of the City Code of the City of Cumming, Iowa.

**G. TRAVEL EXPENSES.** Employee's travel expenses shall be provided according to the City's policy.

**H. RETIREMENT.** The Employee and Employer shall participate and contribute in the usual and customary monetary amounts into the State of Iowa Retirement System (IPERS) or at Employee's request other retirement programs. In the event that Employee declines to participate in IPERS he shall be allowed to participate in a retirement program of his election so long as the amount of the City's contribution shall be equal to that of which the Employee would be allowed under IPERS.

(11) This Contract shall become effective upon execution by the employee, approval by resolution of the City Council and execution by Mayor Tom Becker and shall continue until such time as this contract is terminated by one party or the other pursuant to the terms of this contract.

**IN WITNESS WHEREOF**, the Mayor and the Clerk of the City of Cumming, Iowa have executed this contract on behalf of the City following approval by Resolution \_\_\_\_\_, passed and approved by the City Council of the City of Cumming, Iowa on the \_\_\_\_\_<sup>th</sup> day of \_\_\_\_\_, 2020.

**CITY OF CUMMING, Iowa  
CITY COUNCIL**

**EMPLOYEE**

\_\_\_\_\_  
Tom Becker, Mayor

\_\_\_\_\_  
\_\_\_\_\_

**ATTEST:**

\_\_\_\_\_  
Angie Ritchie, Deputy City Clerk

**Resolution 2020-56  
City of Cumming**

**A Resolution Approving City Administrator Compensation  
Package**

**WHEREAS**, on August 10, 2020 the City Council, City of Cumming, Iowa pursuant to Resolution 2020-54 appointed \_\_\_\_\_ as their City Administrator, and

**WHEREAS**, the City Council, City of Cumming, Iowa has the authority to fix compensation of appointive officers and employees, and

**WHEREAS**, \_\_\_\_\_ upon acceptance of this \_\_\_\_\_ time position and is authorized hours not to exceed \_\_\_\_\_ per pay period. Pay periods are for 2 weeks beginning on Monday and ending on the following Sunday. In addition, the City Administrator is authorized up to \_\_\_\_\_ hours additional time per pay period for regular or special council meetings, and

**WHEREAS**, This position is \_\_\_\_\_ and holidays or other special days as outlined in the employee handbook are \_\_\_\_\_, and

**WHEREAS**, \_\_\_\_\_ shall be reimbursed for travel expenses when using his/her own personal vehicle while attending to City business and that the rate paid for this mileage will be the same as established in Resolution 2012-22, Resolution to Establish Mileage Reimbursement, approved on 2/27/12, and

**NOW, THEREFORE BE IT RESOLVED** that the City Council authorizes the compensation to \_\_\_\_\_ at \$ \_\_\_\_\_ per \_\_\_\_\_

Passed and approved this 10<sup>th</sup> day of August, 2020.

\_\_\_\_\_  
Tom Becker, Mayor

Attest: \_\_\_\_\_  
Angie Ritchie, Deputy Clerk

Job Description  
City of Cumming, Iowa

Position: City Administrator/City Clerk/Finance Director  
Reports to: Mayor and City Council  
Date: February 10, 2020  
FLSA Status: Exempt

**POSITION SUMMARY:**

Performs a wide variety of public administration duties, as specified in Iowa State law or local ordinances, or as directed by the City Council and/or Mayor in the daily operations of the city government. Advises the Mayor/City Council on current issues and future needs of the City and makes recommendations and offers alternative solutions. Coordinate and implement the directives and goals of the Mayor and City Council. Perform the duties and responsibilities of the City Clerk and City Finance Director as provided for in the City Code of Ordinances. Supervise Deputy City Clerk and other employees the City may employ in the future.

**ESSENTIAL JOB DUTIES:**

1. Keep the Mayor and Council informed by collecting, analyzing, and summarizing information, remain accessible, answer questions and provide information for requests to ensure smooth operation of the City.
2. Develop and recommend an annual budget for review and approval by the Mayor and City Council. Finalize the budget for submission with the State after Council approval.
3. See that all laws, ordinances, resolutions, Council and Mayor directives and approved operational policies are appropriately enforced.
4. Document payments for City bills, maintain City billing system.
5. Responsible for the supervision and performance of all contracts for work and services done for the City, except as specified otherwise in the construction or service program involved.
6. Maintain an accounting of all obligations, agreements, commitments, and other contractual agreements involving the City and report to the Mayor and Council any issues.
7. Direct the purchasing of all commodities, materials, supplies, capital outlay and services for the City which have been budgeted.
8. Coordinate City projects and keep Council/Mayor informed of actions required by Council and progress on projects. Work with Planning and Zoning Commission, engineers, city legal counsel, developers, and others as necessary to ensure smooth completion of projects.
9. Maintain a good working relationship with citizens, community groups, other cities, League of Iowa Cities, and other State, federal, or local groups and organizations, and attend meeting on behalf of the City as necessary.
10. Serves as Zoning Administrator.
11. Attend City Council meetings, prepare agendas and supporting documentation. Attend Planning and Zoning Commission meetings and Board of Adjustment meetings.
12. Perform other duties as directed by the Council and Mayor.

**KNOWLEDGE, SKILLS AND ABILITIES REQUIRED:**

The individual must possess the following knowledge, skills, and abilities or be able to explain and demonstrate they can perform the essential functions of the job, using some other combination of skills and abilities.

1. Knowledge of principles, practices, and objectives of public administration including knowledge of financial administration.

2. Knowledge of municipal operation including public relations, economic development, land use, urban planning and zoning.
3. Knowledge of and ability to interpret and apply local, state and federal laws relating to cities.
4. Ability to consult expert sources and documents.
5. Skill in using modern office equipment, including computers and word-processing, spreadsheets, and telecommunications equipment; as well as social media.
6. Ability to communicate clearly, both orally and in writing.

ENTRY REQUIREMENTS:

1. Bachelor's Degree in public administration, accounting, business administration or comparable field.
2. Work experience in public sector work, preferably municipal work, desired.
3. Background in accounting and government finance.
4. Working knowledge of land use planning, zoning and development.
5. Valid Iowa motor vehicle operator's license.
6. Background check and drug testing required as condition of employment.
7. Must be bondable.

This position is generally 40 hours per week, Monday through Friday, plus the attendance at meetings of the City Council, Planning and Zoning Commission, Board of Adjustment, and other meetings that may occur from time to time and are held in the evening.

The City retains the authority to change the job duties at any time. The employee is an at will employee and the job description does not constitute an employment agreement between the City and the employee.

City of Cumming, Iowa  
City Administrator/City Clerk

Announcement/Advertisement:

The City of Cumming, Iowa is seeking a City Administrator/City Clerk. Located off I-35, Cumming shares borders with West Des Moines on the north and Norwalk on the east and is projecting significant growth in the near future. The City is seeking an energetic and self-starter individual who can serve as City Administrator and City Clerk.

Salary range is \$55,000 to \$70,000, depending upon qualifications. This individual will be responsible to oversee the work of the Deputy City Clerk, supervision of city contracts, oversight of city property, management of capital improvement projects, and keeping the five-member city council and Mayor fully advised of the city's financial condition and overall needs.

Due to the anticipated growth, this individual will work closely with developers, engineers, legal counsel, financial advisors, planning and zoning commission, and others to coordinate development.

Qualifications include a four-year college degree in public or business administration or related field. Experience in public sector work desirable.

Job description can be found on the City's web site at [www.cumming-iowa.com](http://www.cumming-iowa.com).

Submit a resume, cover letter, salary history and work references to Donald Sandor at [sandord2020@gmail.com](mailto:sandord2020@gmail.com).

Applications will be accepted until the position is filled with the first review of applicants on March 19, 2020.

**RESOLUTION 2020-19  
City of Cumming**

**A RESOLUTION AUTHORIZING CITY PAY RANGES**

**Whereas** the City Council of the City of Cumming, Iowa finds that the following pay ranges for the City of Cumming\*:

	Council Meetings**	Other Meetings**	Travel***	Hourly Rate	Salary Range
Mayor	\$57.59	\$17.30	\$57.5	N/A	N/A
Council	\$34.56	\$17.30	\$57.5	N/A	N/A
City Administrator /Clerk			\$57.5	TBD	TBD
Deputy Clerk			\$57.5	\$10.00-\$25.00	
*Mayor and Council pay ranges shall be in effect as of July 1, 2020 Deputy Clerk pay ranges shall be in effect immediately, February 10, 2020					
** Chapters 15 & 17, Cumming Code of Ordinances – CPI increase (as of July 1, 2019) 3.3%					
*** IRS Mileage Rate for 2020					

Passed and approved this 10<sup>th</sup> day of February, 2020.

\_\_\_\_\_  
Tom Becker, Mayor

Attest:

\_\_\_\_\_  
Donald Sandor, City Administrator



# RECOMMENDATION BY THE PLANNING & ZONING COMMISSION

Recommendation:  Aye {Yes} 5  Nay {No} 0  
How Many How Many  
Adopt Recommend City Council Adopt Revised  
Chapter 122: Peddlers, Solicitors and Transient Merchants  
New Section 122.10 regarding Mobile Food vendors and  
Revisions to 122.05 Registration fees and 122.06 Transient Merchant  
Board.

**Further Review Requested:**

By Mayor/City Council     
  By City Attorney     
  By City Planner

**Additional Information:**

One change to ordinance presented to PZC, 122.10(5)(m)  
changed from 1 allowable sign to 2 signs

**Requested Action To Be Taken By The City Council:**

Motion  
 Resolution  
 Ordinance

**Date:** 7/28/2020     
 **Signature:** Carole K. Williams  
 Chair/Vice Chair/Secretary      City Attorney

**Resolution 2020-57  
City of Cumming**

**Set a Date for a Public Hearing to Amend the  
Code of Ordinances, City of Cumming, Iowa, by Amending  
Chapter 122 Peddlers, Solicitors and Transient Merchants**

**WHEREAS**, The City Council desires to consider amending Chapter 122 – Peddlers, Solicitors and Transient Merchants, and

**WHEREAS**, Iowa Law requires a Public Hearing be held before the Council prior to amending any changes in the Code of Ordinances,

**NOW, THEREFORE, BE IT RESOLVED**, by the City Council of City of Cumming, Iowa, as follows:

Section 1. This Council will meet at the Cumming City Hall, Cumming, Iowa, on the 14<sup>th</sup> day of September, 2020, 7:00 P.M. at which time and place it will hold a public hearing on amending the Code of Ordinances for the City of Cumming.

Section 2. The City Clerk shall post notice of said hearing, which posting shall be at the three public places in said City which have been permanently designated by ordinance, and such posting shall be at least 4 days but not more than 20 days prior to any action by the City Council.

Passed and approved this 10<sup>th</sup> day of August, 2020.

\_\_\_\_\_  
Tom Becker, Mayor

Attest:

\_\_\_\_\_  
Angie Ritchie, Deputy Clerk

# **NOTICE OF PUBLIC HEARING**

## **CITY OF CUMMING**

### **AMENDING CHAPTER 122 PEDDLERS, SOLICITORS AND TRANSIENT MERCHANTS**

Notice is hereby given that the City Council of the City of Cumming, Iowa, will conduct a public hearing on Monday, September 14, 2020, 7:00 P.M., at City Hall, 649 N. 44<sup>th</sup> Street, Cumming, Iowa, to receive comments on the following:

Amending the City of Cumming's Code of Ordinances,  
Chapter 122 Peddlers, Solicitors and Transient Merchants

Additional information regarding this request may be obtained by contacting the Deputy Clerk at 981-9214.

Anyone wishing to comment on this matter should attend this hearing or submit written comments at any time prior to the hearing. Send comments to City of Cumming, P. O. Box 100, Cumming, IA, 50061

## CHAPTER 122

### PEDDLERS, SOLICITORS AND TRANSIENT MERCHANTS

122.01 Purpose	122.06 Transient Merchant Bond
122.02 Definitions	122.07 Time Restriction
122.03 Registration Required	122.08 Exemptions
122.04 Registration Requirements	122.09 Charitable and Nonprofit Organizations
122.05 Registration Fee	122.10 Mobile Food and Beverage Vendors

#### **122.01 PURPOSE.**

The purpose of this chapter is to protect residents of the City against fraud, unfair competition and intrusion into the privacy of their homes by licensing and regulating peddlers, solicitors and transient merchants.

#### **122.02 DEFINITIONS.**

For use in this chapter the following terms are defined:

1. "Peddler" means any person carrying goods or merchandise who sells or offers for sale for immediate delivery such goods or merchandise from house to house or upon the public street.

2. "Solicitor" means any person who solicits or attempts to solicit from house to house or upon the public street any contribution or donation or any order for goods, services, subscriptions or merchandise to be delivered at a future date.

3. "Transient merchant" means any person who engages in a temporary or itinerant merchandising business and in the course of such business hires, leases or occupies any building or structure whatsoever, or who operates out of a vehicle which is parked anywhere within the City limits. Temporary association with a local merchant, dealer, trader or auctioneer, or conduct of such transient business in connection with, as a part of, or in the name of any local merchant, dealer, trader or auctioneer does not exempt any person from being considered a transient merchant.

#### **122.03 REGISTRATION REQUIRED.**

Any person engaging in peddling, soliciting or in the business of a transient merchant in the City without first registering with the City as herein provided is in violation of this chapter.

#### **122.04 REGISTRATION REQUIREMENTS.**

The registration shall be in writing, filed with the Clerk, and shall set forth the following information:

1. The person's name, permanent and local address and business address if any, driver's license number and vehicle description.

2. The person's employer, if any, and the employer's address, the nature of the business and the length of time such business will be carried on in the City.

3. The names of all people who are to be working within the City and their vehicle descriptions and license numbers.

#### **122.05 REGISTRATION FEE.**

A registration fee of \$25.00 per application shall be paid at the time of registration to cover the cost of investigating the facts stated therein.

#### **122.06 TRANSIENT MERCHANT BOND.**

1. Except as provided in paragraph (3) below, no transient merchant license shall be issued until the applicant has delivered to the city clerk a cash bond for no less than \$200.00. The bond shall be held to indemnify and pay the city any penalties or costs incurred in the enforcement of any of the sections of this article and indemnify or

reimburse any purchaser of goods, wares, merchandise or stock for any judgment which may be obtained by a purchaser for damages in any action commenced within three months from the date of purchase, due to misrepresentations as to the kind, quality or value of such goods, wares, merchandise or stock, whether the misrepresentations were made by the owner or by his or her servants, agents or employees, either at the time of making the sale or through any advertisement of any character, printed or circulated, with reference to such stock of goods, wares or merchandise or any part thereof.

2. A single bond may be used for all licenses obtained by the same transient merchant.

3. The balance of the bond shall be released by the city clerk and returned to the applicant upon request by the applicant at any time more than four months after expiration of all transient merchant licenses for which the cash bond was provided, unless the city clerk has received notice of a pending action in the state or federal courts seeking a judgment upon a claim eligible for payment from the bond. Except as otherwise provided by court order, the city clerk shall not release any bond during the pendency of any such action.

#### **122.07 TIME RESTRICTION.**

Peddlers and solicitors shall conduct business in the City only during daylight hours.

#### **122.08 EXEMPTIONS.**

The following are excluded from the application of this chapter.

1. Newspapers. Persons delivering, collecting for or selling subscriptions to newspapers.

2. Club Members. Members of local civic and service clubs, Boy Scout, Girl Scout, 4-H Clubs, Future Farmers of America and similar organizations.

3. Local Residents and Farmers. Local residents and farmers who offer for sale their own products.

4. Students. Students representing the Norwalk Community School District conducting projects sponsored by organizations recognized by the school.

5. Route Sales. Route delivery persons who only incidentally solicit additional business or make special sales.

6. Resale or Institutional Use. Persons customarily calling on businesses or institutions for the purposes of selling products for resale or institutional use.

#### **122.09 CHARITABLE AND NONPROFIT ORGANIZATIONS.**

Authorized representatives of charitable or nonprofit organizations operating under the provisions of Chapter 504 of the *Code of Iowa*, or political candidates for State, local or Federal office desiring to solicit money or to distribute literature are exempt from the requirements of Sections 122.04 and 122.05. All such organizations or individuals are required to submit in writing to the Clerk the name and purpose of the cause for which such activities are sought, names and addresses of the officers and directors of the organization, and the period during which such activities are to be carried on.

#### **122.10 MOBILE FOOD AND BEVERAGE VENDORS**

1. Mobile Food Unit Licensing: It shall be unlawful for any person to engage in the sale of food or beverages to the public from a temporary or mobile facility located on public property within the corporate limits of the City of Cumming without first obtaining a mobile food unit license from the city, in addition to any other state, federal, or county permits, certifications and licenses.

Mobile food units located on private property are allowed with a transient merchant permit.

A. A mobile food unit license is an annual license that expires on April 15 each year and must be renewed at least 5 days prior to the first event after that date.

B. Each mobile food unit shall be licensed separately. No license transfer is allowed.

C. Although certain activities may be exempt from the licensing requirements of this chapter, any food service to the public in the City of Cumming shall comply with all other local, county and state requirements for health inspections, licensing, safety and fire code requirements.

D. The following shall be exempt from this requirement:

(1) Catering businesses.

(2) Grilling and food preparation activities, including mobile food units, of brick and mortar establishments on the establishments' premises for immediate consumption by patrons or employees.

(3) Concession stands associated with sports or recreational venues that have been approved as part of a site plan.

2. License Fee: At the time of the submittal of a license application, the applicant shall pay to the city clerk's office the applicable license and permit fees in addition to any application fees.

A. The city council shall establish the amount of the license fee by resolution.

B. Any licensee who surrenders their license prior to the date of expiration shall not be entitled to a refund of any portion of the fee.

3. Fire Department Inspection:

A. All mobile food units that have cooking facilities with grease laden vapors (class III and class IV state licenses) shall be inspected by the Norwalk fire department prior to initiation of business operations within the city. However, at the discretion of the city clerk's office the city may accept the inspection of the mobile food unit by another Iowa Fire Department.

B. Inspections are required annually and prior to submittal of a license application to the city. It shall be the obligation of the mobile food vendor to schedule the inspection with the fire department.

C. Upon completion of the annual fire inspection, if the fire department determines that the mobile food unit passes the inspection, the Fire Chief or his/her designee shall sign the mobile food unit vendor license application and identify any conditions for operation as deemed appropriate as a result of said inspection.

4. Mobile Food Unit Vendor Annual Licensing Application:

A. License Required: All mobile food vendors operating on public property within the City of Cumming must obtain a mobile food vendor license from the city.

Exception: Community events sponsored by or approved by City Council. Application requests shall be filed with the city clerk's office on the form provided by the city. No application request shall be accepted for filing and processing unless it conforms to the requirements of this title. This would include a complete and true application and all of the required materials and information prescribed, accompanied by the appropriate fees.

B. Submission Time Frame: Applications must be submitted not less than five (5) business days prior to the proposed start date of the mobile food unit activities. The city reserves the right to reject any applications that have not been timely submitted to the city. The city clerk shall have the discretionary right to accept an application made less than five (5) business days prior to desired start date.

C. Additional Approvals: Receiving approval of a mobile food unit license from the city shall not preclude, supersede, circumvent, or waive the applicant's responsibility to obtain any additional permits, licenses, and approvals for other applicable local, state, and federal regulations.

D. Application Contents: Application shall be made on a form provided by the city and shall include:

- (1) Full name of the applicant.
- (2) Applicant's contact information including mailing address, phone numbers and e-mail address.
- (3) State health inspection certificate with the classification level of the state license identified.
- (4) Description of the kitchen facilities, cooking facilities, preparation area, safety features (suppression system, etc.) of the mobile food unit.
- (5) Photographs of the mobile food unit.
- (6) Make, model and year of vehicle to be used.
- (7) County, state and license plate number.
- (8) The length and width of the vehicle.
- (9) Fire department signature on application confirming a passing fire department inspection.
- (10) Application and license fee(s)

E. Applications Deemed Withdrawn: Any application received shall be deemed withdrawn if it has been held in abeyance, awaiting the submittal of additional requested information from the applicant, and if the applicant has not communicated in writing with the city and made reasonable progress within thirty (30) days from the last written notification from the city to the applicant. The application fee is nonrefundable. Any application deemed withdrawn shall require submission of a new application and fees to begin a new review and approval process.

F. Issuance of License: Upon completion of the review process and a determination of compliance with the applicable regulations, the city clerk will issue a mobile food unit license. The license shall be placed in the upper left (passenger side) of the front windshield or the left front side of a trailer or cart to aid in the visual verification of the licensing for that year.

G. Modification of License After Issuance: Should the mobile food vendor change the food or beverage being offered during the term of an issued license that would change the designation of the mobile food unit to a higher state licensing level classification, a new application and fire inspection shall be required.

5. Mobile Food Units On Public Property: No mobile food unit may be operated on public property except as approved by the city clerk's office.

6. Unattended Mobile Food Unit: No mobile food unit shall be left unattended on any site overnight, unless that property is under the ownership of the operator of the unit and in compliance with all other city code requirements. No mobile food unit shall be allowed to be stored on a site that is not zoned appropriately for storage and warehousing and/or having received prior city council approval through an entitlement process. Any mobile food unit found unattended shall be considered in violation of these regulations and subject to license revocation, municipal infraction, towing, or any other action legally allowed.

7. Music And Sound Making Devices: The use of music or sound making devices as a part of a mobile food unit shall be prohibited, unless expressly allowed as part of an approved event.

8. Mobile Food Unit Performance Standards: Persons conducting business from a mobile food unit must do so in compliance with the following standards:

A. The mobile food vendor must obtain expressed written consent of the property owner to use the business property on which they propose to operate. The written consent must be kept in the unit at all times that the unit is on the property.

B. The operator of the mobile food unit shall display their city license in full view of the public in the unit.

C. Mobile food units within three hundred feet (300') of a residential use or residentially zoned property, shall be limited to hours of operation between seven o'clock (7:00) A.M. and ten thirty o'clock (10:30) P.M.

D. Mobile food units shall be limited to a maximum duration of 12 hours hours per day on any site, unless part of an approved event permit. A mobile food unit shall be at one location a maximum of five (5) consecutive days per week.

E. Only one mobile food unit shall be allowed on a property, unless part of an approved event or the property has received a multiple vendor permit. Mobile food units not under a multiple vendor permit and on adjacent properties must maintain a minimum separation between units of twenty (20) feet.

F. Mobile food units shall serve patrons who are on foot only; no drive-up service to the mobile food unit itself shall be provided or allowed.

G. The mobile food unit must be located on a paved surface, unless approved by the city clerk's office.

H. No mobile food unit may be located on a vacant property or lot with a vacant building.

I. No mobile food unit may operate within two hundred feet (200') of a permanent restaurant or business that primarily engages in food services without the written permission of that business.

J. No alcoholic beverages may be sold as a part of a mobile food unit.

K. Except in zone C-2 any mobile food unit shall maintain a minimum fifteen foot (15') separation from a building as measured to the closest building element including awnings or canopies, tents or membrane structures. Location of the mobile food unit shall not impede pedestrian entering or exiting of a building. In zone C-2 the distance shall be seven (7) feet.

L. Mobile food vendors shall be placed no closer than 15' from a front property line.

M. Signs are limited to those that are attached to the exterior of the mobile unit and must be mounted flat against the unit and not project more than six inches (6") from the exterior of the unit. Only two off premise signs directing patrons to the mobile food unit is allowed.

N. During business hours, the mobile food vendor shall provide a trash receptacle for use by customers.

O. The mobile food vendor shall keep the area around the mobile food unit clear of litter and debris at all times.

P. All mobile food units shall be located in such a manner as to not create a safety hazard, such as blocking emergency access to buildings and the site, obstructing access to fire hydrants and fire department connections, impeding entering and exiting from a building, creating a visual impediment for the motoring public at drive entrances, intersections, pedestrian crossings, etc.



Q. No mobile food unit shall be parked in or otherwise impact access to/from ADA parking stalls.

9. Other Licenses And Permits To Be Maintained: Failure of any applicant to maintain the appropriate county, state and federal licenses and permits, during the term of the local license or permits shall be considered an unlawful act and subject to revocation or any other penalties available to the city.

10. Suspension or Revocation of License: Any license issued under the provisions of this chapter may be suspended or revoked by the city as follows:

A. Grounds: The city clerk may suspend any license issued under this chapter, pending the outcome of an administrative hearing, for any of the following reasons:

(1) The licensee has made fraudulent statements in his/her application for the license or in the conduct of his/her business.

(2) The licensee has violated this chapter or any other chapter of this code or has otherwise conducted his/her business in an unlawful manner.

(3) The licensee has conducted his/her business in such manner as to endanger the public welfare, safety, order, or morals.

(4) The city clerk has received and investigated three (3) or more found complaints during the licensed period related to the manner in which the licensee is conducting business.

B. Notice: The city clerk shall have the licensee served with notice either in person or by regular mail to the licensee's address shown on the license application notifying them of the license suspension, the specific reason(s) for such action, and date and time of hearing with the city clerk to review the particulars of the suspension. The licensee shall be prohibited from any further activities covered by the license until such time that the hearing has been held and a determination of suspension and revocation resolved.

C. Hearing: A hearing shall be conducted by the city clerk not more than five (5) business days after he/she has suspended a license. The licensee and any complainants may be present to determine the truth of the alleged violation of this chapter. Should the licensee or his/her authorized representative fail to appear without good cause, the city clerk may proceed with the hearing and make his/her findings.

D. Revocation: After the city clerk has reviewed the facts, he/she shall revoke a license if he/she finds by the preponderance of the evidence that a violation has occurred. The revocation shall be effective immediately.

E. Appeal: If the city clerk revokes or refuses to issue a license, the licensee or the applicant shall have a right to a hearing before the municipal code hearing officer as provided in Section 122.15 of this code. The municipal code hearing officer may reverse, modify, or affirm the decision of the city clerk.

F. Effect of Revocation: Revocation or denial of any license shall bar the licensee or applicant from being eligible for any license under this chapter for a period of one year from the date of the revocation or denial. There shall be no refund of any fees for any revocation.

11. Penalty: Unless another penalty is expressly provided by this chapter for any particular provision or section, violations of this chapter are simple misdemeanors subject to a fine of not more than five hundred dollars (\$500.00) and may also be punishable as municipal infractions subject to a civil penalty as set forth in this code.

Each day a municipal infraction occurs and/or is permitted to exist constitutes a separate offense. Police officers, code enforcement officers and the police chief's designees shall have the authority to issue citations for violations of this chapter, and shall have the discretion to enforce this chapter as either a simple misdemeanor or municipal infraction.



City of Norwalk  
Fire Department  
1100 Chatham Avenue  
Norwalk, IA 50211  
Office: (515) 981-4316  
Fax: (515) 981-4779  
[www.norwalk.iowa.gov](http://www.norwalk.iowa.gov)

**May 18, 2020**

**City of Cumming  
Attn: Mayor Tom Becker  
649 N 44<sup>th</sup> St  
Cumming, IA 50061**

**RE: Levy Increase**

Dear Mayor,

The City of Norwalk and the Norwalk Fire Department have a long standing agreement of providing fire and EMS services to the City of Cumming. Over recent years the City of Norwalk has increased the staffing and capabilities of the Fire Department to include full time personnel and additional ambulances to accommodate growth and plan for future expansion. Through our budget review process we have found that Norwalk taxpayers are funding fire and EMS at a levy of \$1.32 while Cumming residents are paying a rate of .68. In our contract that we renewed this past year we discussed an increase for future agreements to achieve equity across all agencies receiving Norwalk services.

It has been the direction of Norwalk elected officials to propose a more amicable solution to all customers of Norwalk Fire Department and EMS Services to gradually increase the levy rate to support the services provided. As of October 1, 2020 an updated service agreement will reflect the newly proposed levy rate for the City of Cumming to be .86, an increase of .18 over current rates. This agreement will also state that the levy rate will continue to increase of .18 annually until the levy reaches \$1.32 to match Norwalk taxpayers. This adjustment will ensure that the Norwalk Fire Department is able to continue to provide the high level of services that the citizens of Cumming have come to expect from this partnership.

Please feel free to contact my office with any questions at 515-981-4316 or via email at [rcoburn@norwalk.iowa.gov](mailto:rcoburn@norwalk.iowa.gov).

Respectfully,

Ryan Coburn  
Fire Chief, City of Norwalk

**Resolution 2019-49**  
City of Cumming

Approval and Authorization of a 28E Intergovernmental Agreement between the City of Cumming and the City of Norwalk Regarding Fire Protection and Emergency Medical Services

**WHEREAS**, the City of Cumming is in need of Fire Protection and Emergency Medical Services (EMS) for its residents, and is empowered and required by State Law to provide for such services, and

**WHEREAS**, the City of Norwalk has an established Fire/EMS department and has agreed to provide such services consistent with the level required by the Iowa Code to the City of Cumming, and

**WHEREAS**, The City of Cumming shall pay the City of Norwalk for consideration of providing such services an amount equal to forty and one-half cents \$0.405 for fire protection and twenty and one-fourth cents \$0.2025 for emergency medical services, per thousand dollars of net assessed value of taxable property for the given fiscal tax year, and

**WHEREAS**, The full text of the agreement is found in a document entitled "*Fire and Emergency Medical Services Contract Agreement Pursuant to Iowa Code Section 28E Between the City of Cumming, Iowa and City of Norwalk, Iowa*", and the City of Cumming entered into the 9<sup>th</sup> day of December, 2019, and

**WHEREAS**, Chapter 28E of the Code of Iowa provides for governmental bodies to enter into agreements for joint cooperation in the matters of mutual benefits, and

**WHEREAS**, the City Council, City of Cumming, Iowa, does believe it is in the best interest of the City of Cumming, Iowa, to extend said contract for Fire/Emergency Medical Services until June 30, 2020, and

**THEREFORE, BE IT RESOLVED**, by the City Council that the Mayor and City Clerk are hereby authorized, and directed to execute and attest, respectively, said 28E Intergovernmental Agreement for Fire Protection and Emergency Medical Services, for and on behalf of the City of Cumming, Iowa.

Passed and approved this 9<sup>th</sup> day of December, 2019.

  
\_\_\_\_\_  
Tom Becker, Mayor

Attest:

  
\_\_\_\_\_  
Angie Ritchie, Deputy Clerk

**COPY**

**FIRE AND EMERGENCY MEDICAL SERVICES CONTRACT AGREEMENT PURSUANT TO  
IOWA CODE CHAPTER 28E BETWEEN THE CITY OF CUMMING, IOWA AND THE CITY OF  
NORWALK, IOWA**

This Fire and Emergency Medical Services contract agreement (hereinafter "Agreement") is made and entered into as of this 9<sup>th</sup> day of December, 2019, by and between the City of Cumming, an Iowa municipal corporation; and the City of Norwalk, an Iowa municipal corporation.

WHEREAS, the cities of Cumming and Norwalk have previously entered into Fire/Emergency Medical Services contracts, most recently dated August 17, 2017; and

WHEREAS, the cities of Cumming and Norwalk desire to reaffirm and extend the terms and conditions of the Fire/Emergency Medical Services contract for a new one-year term pursuant to Iowa Code 28E.32.

NOW, THEREFORE, the parties to this Agreement hereby consent and agree as follows:

**ARTICLE 1. GENERAL**

**Section 1. Purpose.** In recognition of the need to protect life and property from the devastating effects of fire and/or medical emergency, the purpose of this Agreement is for the City of Norwalk to provide for fire protection and emergency medical services for all property within the City of Cumming, except as may be provided herein.

**Section 2. Term.** The term of this Agreement shall commence July 1, 2019. This agreement shall thereafter remain in full force and effect for a term of one year, but may be amended or terminated prior to the expiration of the one-year term resolution by the City Council of Cumming or the City Council of Norwalk, or as may otherwise be provided in this Agreement.

The Parties agree that this Agreement is meant to be temporary until a more long-term agreement can be entered into at a later date. The parties agree that eighteen (18) to twenty-four (24) months from the date of this agreement, a new agreement will be negotiated between the respective agencies for consideration.

**Section 3. No Separate Legal Entity or Property Disposition.** No separate legal entity is created by this Agreement and no personal property shall be acquired by the City of Cumming or the City of Norwalk. The City of Norwalk will own, maintain, house and staff the fire protection and other emergency equipment used under this Agreement.

**ARTICLE 2. FIRE ENFORCEMENT AND EMERGENCY MEDICAL SERVICES AGREEMENT**

**Section 1. Fire Enforcement and Emergency Medical Services.** The City of Norwalk agrees to provide fire suppression protection and emergency medical response services for all property

within the City of Cumming consistent with the level of service required by the Iowa Code unless the required service is unavailable or otherwise engaged at the time.

**Section 2. Mutual Aid.** In the event the required service is unavailable or otherwise engaged at the time, Norwalk shall follow its normal procedures to invoke its mutual aid agreements with other departments.

**Section 3. Compensation.** The City of Cumming agrees to pay forty and one-half cents (\$0.405) for fire service, and twenty and one-fourth cents (\$0.2025) for rescue services, per thousand dollars of net assessed value of taxable property within the City of Cumming as determined by Warren County levy authority. This amount shall be payable bi-annually on a fiscal year basis. In addition to the compensation herein, the City of Norwalk reserves the right to charge the individual user of the services provided pursuant to fee schedules outlined in the Norwalk Code.

### ARTICLE 3. REVIEW

**Section 1. Review Authority.** Fire protection personnel shall work under the supervision of the Norwalk Fire Chief and equipment furnished by the City of Norwalk. Disaster assistance shall be provided in accordance with the City of Cumming Emergency Operations Plan. The Norwalk Fire Chief shall provide to the City of Cumming timely reports or attendance at council meetings as needed or requested. A Fire Advisory Board shall be created for strictly advisory and communication purposes and shall not be responsible for the administration or operations of the Fire Department.

### FILING AND RECORDING

This Agreement and the Resolution approving this Agreement from the cities of Cumming and Norwalk shall be filed within ten days of later date of approval by the approving entities. Pursuant to Iowa Code 28E.8, this Agreement shall also be filed with the Iowa Secretary of State and recorded in the Office of the Warren County Recorder.

IN WITNESS WHEREOF, the City of Cumming and the City of Norwalk have caused this Agreement to be executed by their respective Council and Board.

City of Cumming, Iowa

Tom Becker  
By: \_\_\_\_\_

It's: Mayor

Angie Ritchie  
By: \_\_\_\_\_

It's: Deputy Clerk

STATE OF IOWA )  
  ) SS:  
WARREN COUNTY )

On this 13<sup>th</sup> day of December, 2019, before me, the undersigned, a Notary Public and for the State of Iowa, personally appeared Tom Becker and Angie Ritchie, to me personally known, who, being by me duly sworn, did say that they are the Mayor and Deputy Clerk respectively, of the City of Cumming, Iowa; a municipal corporation; that the seal affixed to the foregoing instrument is the corporate seal of the corporation, and that the instrument was signed and sealed on behalf of the corporation, by authority of its City Council, as contained in the Resolution adopted by the City Council under Roll Call No. 2019-49 on the 9th day of December, 2019 and Tom Becker and Angie Ritchie acknowledged the execution of the instrument to be their voluntary act and deed and the voluntary act and deed of the City of Cumming, by it and by them voluntarily executed.

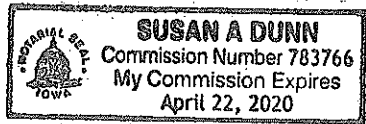

\_\_\_\_\_  
Notary Public in and for said State

City of Norwalk, Iowa

Tom Phillips

By: Tom Phillips  
It's: Mayor

Lindsey Offenburger

By: Lindsey Offenburger  
It's: City Clerk

STATE OF IOWA )  
                          ) SS:  
WARREN COUNTY )

On this 16 day of February, <sup>2020</sup>~~2019~~, before me, the undersigned, a Notary Public and for the State of Iowa, personally appeared Tom Phillips and Lindsey Offenburger, to me personally known, who, being by me duly sworn, did say that they are the Mayor and City Clerk respectively, of the City of Norwalk, Iowa; a municipal corporation; that the seal affixed to the foregoing instrument is the corporate seal of the corporation, and that the instrument was signed and sealed on behalf of the corporation, by authority of its City Council, as contained in the Resolution adopted by the City Council under Roll Call No. 20013 on the 6 day of February 2020, ~~2019~~ and Tom Phillips and Lindsey Offenburger acknowledged the execution of the instrument to be their voluntary act and deed and the voluntary act and deed of the City of Norwalk, by it and by them voluntarily executed.

Kerri Keyte  
Notary Public in and for said State



**COPY**

RECEIVED FEB 18 2020



age under ideal conditions

Orilla

OA4 Siren, 118dB

SE Creekhill Way

Vortex R4 Siren 129dB

Cumming

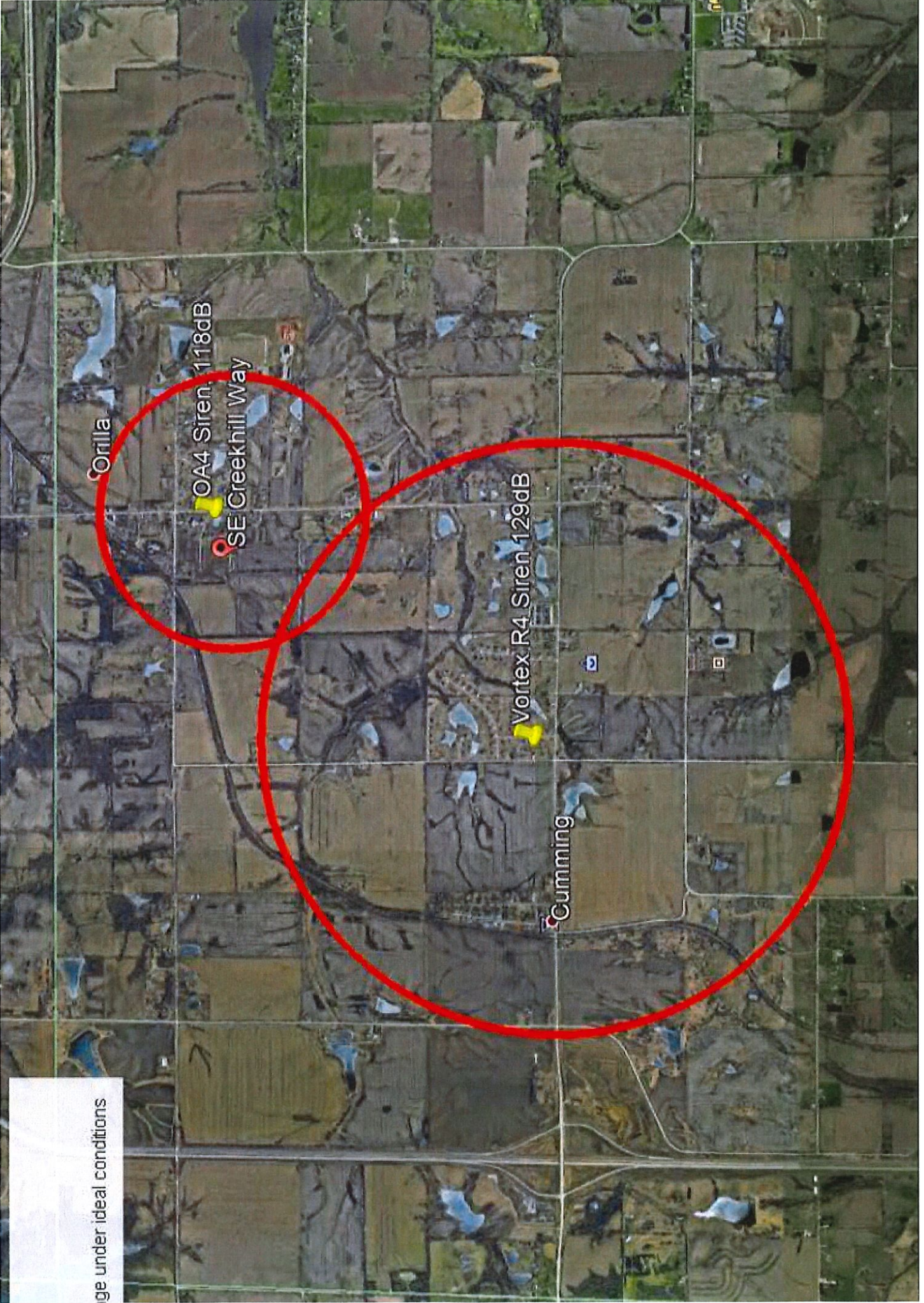

Frontline Plus Fire & Rescue  
DBA/Frontline Warning Systems  
8004 Aetna Avenue NE  
Monticello, MN 55362  
Phone # 763-295-3650 frontlineplus@tds.net  
Fax # 763-295-3650 www.frontlinewarningsystems.com

Date
6/15/2020

Name / Address
City of Cumming, IA Angie Ritchie 515-981-9214 wdcleark@cummingiowa.gov

Terms	Due Date	RFP Contact	POB
Net 30 Days	6/15/2020	AG	

Item	Description	Qty	Cost	Total
	This estimate is a new Outdoor Warning System as listed below. 2 Sirens are included, turn key installation and solar power. No other fees or electrical hookup is required. This is a turn-key project. Sirens will be radio activated from the WestCom WeatherWarn System at Westcom Dispatch, similar to Norwalk and West Des Moines. Setup in dispatch is included in this proposal.			
VORTEX/R4	Siren Equipment: VORTEX/R4 Electronic Outdoor Warning Siren; Rotating siren rated at 129dBc @ 100ft and 70dBc @ 600ft (Est). 4-400watt speaker drivers, ESC2030 Controller, motherboard, amplifiers factory installed in Type I aluminum cabinet.	1	15,250.00	15,250.00T
OA4 Omni Siren	Omni-Alert 4 Outdoor Warning Sirens. Non-rotating siren at 118dB @ 100ft & 70dB at 2800ft. ESC2030 Controller, motherboard, amplifiers factory installed in Type I aluminum cabinet.	1	12,595.00	12,595.00T
C2030NV	10 Digit DTMF VHF High-Band/Narrow Band	2	1,500.00	3,000.00T
POLE TOP BRACKET	VPTB #01-0411446-00. Pole Top Mounting Bracket.	2	295.00	590.00T
PS-12550-U	Power Sonic 12550-U sealed batteries for Whelen Vortex & Omni-Alert sirens.	4	165.00	660.00T
	<b>Services &amp; Installation:</b>			
Installation	Labor for installation of new sirens as listed above	1	4,900.00	4,900.00T
55ft Class II Pole	55ft Class II Pole	2	1,395.00	2,790.00T
SOLAR POWER	Solar Power for Siren; Two (2) 80 Watt Solar Power Panels, bracket, regulator. No external AC power required.	2	1,500.00	3,000.00T
Mobilization	Mobilization of contractor heavy equipment; 60T digger derrick	600	2.00	1,200.00T
Mobilization	Mobilization of contractor heavy equipment; 60ft bucket truck	600	2.00	1,200.00T
Materials	Materials for installation; copper, conduit, bolts, etc.	2	450.00	900.00T
Programming	On Site Programming and Optimization; WestCom setup and programming for two-way feedback with email notification	1	0.00	0.00

QUOTE ONLY. 60 DAYS Above Date.	<b>Subtotal</b>
	<b>Sales Tax (0.0%)</b>
	<b>Total</b>

Frontline Plus Fire & Rescue  
DBA/Frontline Warning Systems  
8004 Aetna Avenue NE  
Monticello, MN 55362  
Phone # 763-295-3650 frontlineplus@tds.net  
Fax # 763-295-3650 www.frontlinewarningsystems.com

Date
6/15/2020

Name / Address
City of Cumming, IA Angie Ritchie 515-981-9214 wdcleark@cummingiowa.gov

Terms	Due Date	REP Contact	FOB
Net 30 Days	6/15/2020	AG	

Item	Description	Qty	Cost	Total
SHIPPING	Freight Shipping	1	735.00	735.00T
Gold Warranty	Warranty: Whelen Gold Warranty: Years 1 & 2: Full parts coverage Years 3 - 5: Full parts coverage with \$75 deductible waived. Exclusions apply. See warranty documentation.	2	0.00	0.00T

QUOTE ONLY. 60 DAYS Above Date.		<b>Subtotal</b>	\$46,820.00
		<b>Sales Tax (0.0%)</b>	\$0.00
		<b>Total</b>	\$46,820.00

# VORTEXR4

# WHELEN®

## All Hazard High-Power Siren System

**Whelen's VORTEXR4 Series All Hazard High Power Sirens provide an economical alternative for powerful siren communication without compromising quality.**

### SYSTEM FEATURES

- VORTEXR4 - Speaker with Four Speaker Cells Active
- Two Compartment (Type I) Natural Finish Aluminum Cabinet
- 129dB @ 100'
- VORTEXR4 Speaker Includes Four High Efficiency 400 Watt Speaker Drivers
- 50' Cable Included
- Battery Powered, Minimum of 15 Minutes of Full Power Output with Batteries of Our Recommendation
- AC Temperature Compensated 5 Amp Battery Charger
- Local Controls or Remote Controls
- Four Tone-Only Power Amplifiers
- Gear Driven Rotor
- Electronic Siren Controller
- Tone Generator
- Timer
- Local Control Push Buttons
- Rotor Relay Control
- SI TEST\*
- Low Battery Alarm
- Battery Tray
- Lightning Arrestor
- Six Standard Public Warning Tones - Wail, Whoop, Attack, Hi-Lo, Alert, Airhorn

### SYSTEM OPTIONS

- VSBC80 - Solar Power ⓪
- BSETVOR - 2ea Whelen Approved Batteries
- VPTB - Speaker Pole Top Bracket
- Alternate Tone Set

#### NOTES:

- ⓪ Solar power option, 2 - 80 watt panels, mounting bracket and regulator.

### SIREN ACTIVATION CONTROLS

Our VHF High and UHF siren activation control packages include the following:

- Radio
- Radio Interface
- Tone Squelch
- 2-3dB Gain Omni-Directional Antenna with Bracket
- 35' of RG58 Antenna Cable
- Polyphaser
- SI TEST\*

Other features are dependant upon one or two-way controls. Whelen equipment can be interfaced with many different types of two-way radio communications products and systems including 800Mhz trunking, Motorola's MOSCAD, FSK, Narrow-Band and VHF Low Band. The following is available as standard options. Contact factory for special applications.

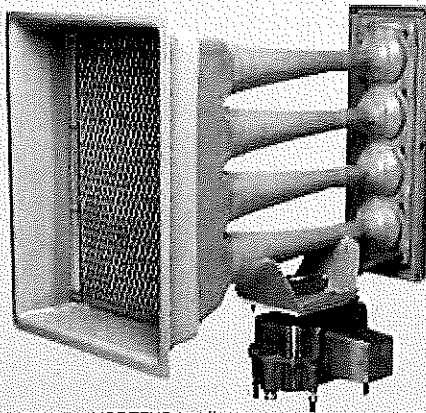

VORTEXR4 cell speaker housing mounted on rotor.

### ONE-WAY CONTROLS

- VAUXIN - Auxiliary Board for Contact Closure Activation
- VD2020LL - 10 Digit DTMF Landline Activation
- VD2020H - 10 Digit DTMF VHF High Band / 150-170 Mhz
- VD2020U - 10 Digit DTMF UHF / 450-470 Mhz
- VORTT - Two-Tone Sequential Option

### TWO-WAY CONTROLS

- VAUXCS - Two-Way Contact Closure Activation and Status Board
- VC2020LL - Two-Way Landline Activation
- VC2020H - 10 Digit DTMF VHF High Band / 150-170 Mhz
- VC2020U - 10 Digit DTMF UHF / 450-470 Mhz
- VC2020NH - 10 Digit DTMF VHF High Band Narrow-Band
- VC2020NU - 10 Digit DTMF UHF Narrow-Band

### Options:

- VFSKXMOD - Converts the Siren Activation Controls to FSK Format
- VSTATUS - Cabinet Window LED Status Indicator
- VPGINT - Paging Interface to Interface Whelen Tones with Existing Paging Systems
- VINTRU - Intrusion Alarm (available with two-way only)



TYPE I ELECTRONIC CABINET (with service door open shows control panel and battery tray with optional batteries).

# VORTEXR4

## Specification Data

Component	Height Inches (CM)	Width Inches (CM)	Depth Inches (CM)	Weight Lbs. (kg)
VORTEXR4 Speaker & Rotor	49.0 (124.5)	28.5 (72.4)	56.0 (142.2)	234 (106.1)
Electronics Cabinet - Type I	32.5 (82.6)	22.5 (57.2)	10.5 (26.7)	83 (37.7)*
Pole Top Bracket (Optional)	30.0 (76.2)	12.0 (30.5)	10.0 (25.4)	71 (32.3)

\* Less batteries. Two batteries, Delco DC74, add 90 Lbs. (40.9kg)

### ELECTRICAL

- Battery charger input: 120VAC, 60Hz, 7A Fuse
- Battery charger output: 28VDC, 5A#
- Batteries: 2-12V, 60AH Lead Calcium (user supplied)
- Standby current: 40mA,
- Rotor motor: <1A, 24VDC
- Operating current: 88A, 24VDC
- Power amplifier output power: 1600 Watts
- # UL recognized component

### ENVIRONMENTAL

- Operating Temperature: -35C to +60C
- Storage Temperature: -65C to +125C
- Humidity, Non Condensing: 0 to 95%

### ORDERING INFORMATION

#### BASIC SYSTEM INCLUDES ALL OF THE FOLLOWING:

- VORTEXR4 - Speaker Assembly & Electronics Cabinet

#### OPTIONS:

- VAUXIN - Auxiliary Board for Contact Closure Activation
- VAUXGS - Auxiliary / Status Control Board for Contact Closure Activation and Status
- VD2020LL - VD2020H, VD2020U - One-Way Radio Control ①
- VC2020LL, VC2020H, VC2020U - Two-Way Radio Control / Status Monitoring, COMM/STAT\* ①
- VC2020NH, VC2020NU - Two-Way Narrow-Band Radio Control / Status Monitoring, COMM/STAT\* ①
- VORTT - Two-Tone Sequential
- VFSKXMOD - FSK Format
- VSTATUS - Cabinet Window LED Status Indicator
- VPGINT - Paging Interface to Interface Whelen Tones with Existing Paging Systems
- VINTRU - Intrusion Alarm
- VSBC80 - Solar Power ②
- VPTB - Speaker Pole Top Bracket
- BSETVOR - One Pair of Batteries

#### NOTES

- ① 10 digit DTMF Controls • Landline • VHF High Band/150-170 Mhz • UHF/450-470 Mhz  
Our VHF High and UHF siren activation control packages include tone squelch, radio, radio interface, 2-3dB gain omni-directional antenna with bracket, 35' of RG58 antenna cable and polyphaser.
- ② Solar power option includes 2 - 60 watt panels, mounting bracket and regulator
- ③ Contact Factory

### Acoustic Performance

SPL @ 100': 129dB

Estimated 70dB range: 6,000'

Estimated 60dB range: 12,000'

Note: 100' performance levels listed represent repeatable results within +/-2dB to stated levels.  
Estimated 70dB perimeter is based on the Federal Emergency Management Agency's (FEMA) -10dB per distance doubled path model.

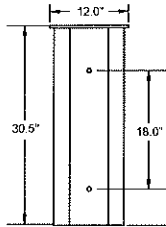
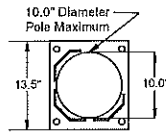
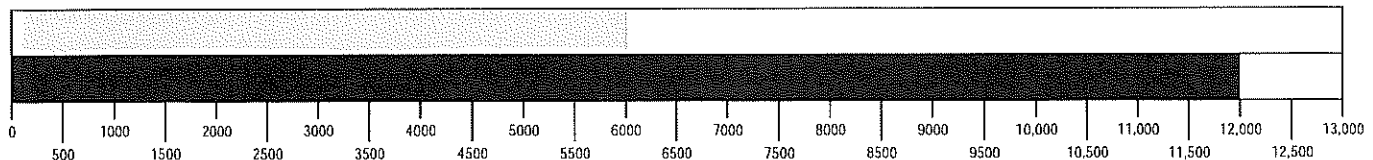

Pole Top Bracket  
(Optional VPTB)

# WHELEN®

ENGINEERING COMPANY, INC.

PUBLIC WARNING PRODUCTS

Route 145, Winthrop Road  
Chester, Connecticut 06412-0684

(860) 526-9504

1-800-637-4736

Fax: (860) 526-4784

Internet: [www.whelen.com](http://www.whelen.com)

e-mail: [iowsales@whelen.com](mailto:iowsales@whelen.com)

Whelen Engineering Company, Inc.  
reserves the right to upgrade its products  
with design improvements without notification.  
Tornado photo courtesy NOAA/NSSL.  
© 2006 Whelen Engineering Company, Inc.  
Printed in the U.S.A.  
041806-11358C

# WHELEN®

## OA4 4 Cell Siren

### All Hazard High-Power Siren System

*Whelen's OMNI-ALERT™ Series provides an economical alternative for powerful omni-directional siren warning without compromising quality.*

#### SYSTEM FEATURES

- OA4 - Four Omni-Directional Speaker Cells Assembled in a Vertical Column
- Speaker Pole Top Mounting Bracket Included
- Two-Compartment (Type I) Natural Finish Aluminum Cabinet
- 118dB @ 100'
- OA4 Speaker Cell Includes Four High Efficiency 400 Watt EZ-PULL™ Speaker Drivers
- 50' Cable Included
- Battery Powered, Minimum of 15 Minutes of Full Power Output with Batteries of our Recommendation
- AC Temperature Compensated 5 Amp Battery Charger
- Local Controls or Remote Controls
- Four Power Amplifiers
- Electronic Siren Controller
- Tone Generator
- Timer
- Local Control Push Buttons
- SI TEST\*
- Low Battery Alarm
- Battery Tray
- Lightning Arrestor
- Six Standard Public Warning Tones - Wail, Whoop, Attack, Hi-Lo, Alert, Airhorn

#### SYSTEM OPTIONS

- OSBC80 - Solar Power<sup>1</sup>
- BSETO - Whelen Approved Batteries
- Alternate Tone Set

#### NOTES:

- <sup>1</sup> Solar power option. 2 - 80 watt panels, mounting bracket and regulator.

#### SIREN ACTIVATION CONTROLS

Our VHF High and UHF siren activation control packages include the following:

- Radio
- Radio Interface
- Tone Squeich
- 2-3dB Gain Omni-Directional Antenna with Bracket
- 35' of RG58 Antenna Cable
- Polyphaser
- SI TEST\*

Other features are dependant upon one or two way controls. Whelen equipment can be interfaced with many different types of two-way radio communications products and systems including 800Mhz trunking, Motorola's MOSCAD, FSK, Narrow-Band and VHF Low Band. The following is available as standard options. Contact factory for special applications.

#### ONE WAY CONTROLS

- OAUXIN - Auxiliary Board for Contact Closure Activation
- OD2020LL - 10 Digit DTMF Landline Activation
- OD2020H - 10 Digit DTMF VHF High Band / 150-170 Mhz
- OD2020U - 10 Digit DTMF UHF / 450-470 Mhz
- OTT - Two Tone Sequential Option

#### TWO WAY CONTROLS

- OAUXCS - Two-Way Contact Closure Activation and Status Board
- OC2020LL - Two-Way Landline Activation
- OC2020H - 10 Digit DTMF VHF High Band / 150-170 Mhz
- OC2020U - 10 Digit DTMF UHF / 450-470 Mhz
- OC2020NH - 10 Digit DTMF VHF High Band Narrow-Band
- OC2020NU - 10 Digit DTMF UHF Narrow Band

#### Options:

- OFSKXMOD - Converts the Siren Activation Controls to FSK Format
- OSTATUS - Cabinet Window LED Status Indicator
- OPGINT - Paging Interface to Interface Whelen Tones with Existing Paging Systems
- OINTRU - Intrusion Alarm (available with two-way only)

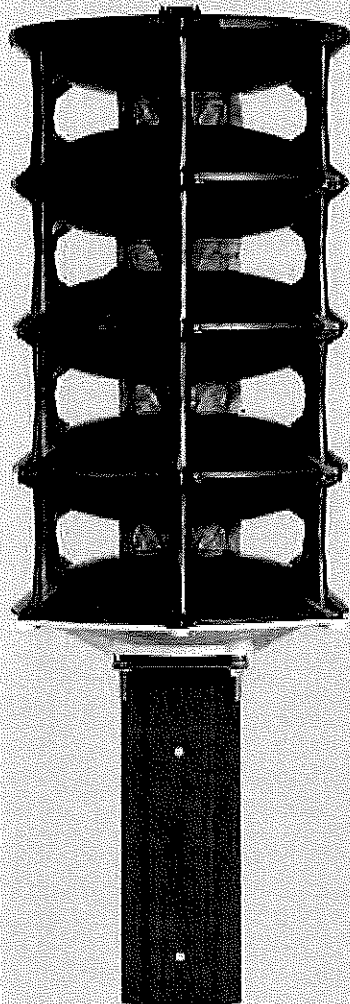

Type I  
Electronic Cabinet



# OA4 Specification Data

Component	Height Inches (CM)	Width Inches (CM)	Depth Inches (CM)	Weight Lbs. (KG)
OA4 Speaker	57.9 (147.1)	33.4 (84.8)	—	254 (115)
Electronics Cabinet - Type I	32.5 (82.6)	22.5 (57.2)	10.5 (26.7)	83 (37.7)*
Pole Top Bracket	30.0 (76.2)	12.0 (30.5)	See Drawing	71 (32.3)

\*Less batteries. Two batteries, Delco DC74, add 90 Lbs. (40.9kg)

## Electrical

- Battery Charger Input: 120VAC, 60Hz, 7A Fuse
- Battery Charger Output: 28VDC, 5A #
- Batteries: 2-12V, 60AH Lead Calcium (user supplied)
- Standby Current: 40mA,
- Operating Current: 89A, 24VDC
- Power Amplifier Output Power: 1600 watts
- # U.L. Recognized Component

## Environmental

- Operating Temperature: -35C to +60C
- Storage Temperature: -65C to +125C
- Humidity, Non-Condensing: 0 to 95%

## Ordering Information

**BASIC SYSTEM INCLUDES ALL OF THE FOLLOWING:**

- OA4 - Speaker Assembly, Electronics Cabinet & Pole Top Bracket

**OPTIONS:**

- OAUXIN - Auxiliary Board for Contact Closure Activation
- OAUXCS - Auxiliary / Status Control Board for Contact Closure Activation and Status
- OD2020LL, OD2020H, OD2020U - One Way Radio Control ①
- OC2020LL, OC2020H, OC2020U - Two Way Radio Control / Status Monitoring, COMM/STAT™ ①
- OC2020NH, OC2020NU - Two Way Radio Control / Status Monitoring, COMM/STAT™ ①
- OTT - Two Tone Sequential
- OFSKXMOD - FSK Format
- OSTATUS - Cabinet Window LED Status Indicator
- OPGINT - Paging Interface to Interface Whelen Tones with Existing Paging Systems
- OINTRU - Intrusion Alarm
- OSBC80 - Solar Power ②
- BSET0 - One Pair of Batteries

### NOTES

- ① 10 digit DTMF Controls • Landline • VHF High Band / 150-170 Mhz • UHF / 450-470 Mhz  
Our VHF High and UHF siren activation control packages include tone squelch, radio, radio interface, 2-3dB gain omni-directional antenna with bracket, 35' of RG58 antenna cable and polyphaser.
- ② Solar power option includes 2 - 80 watt panels, mounting bracket and regulator

## Acoustic Performance

SPL @ 100': 118dB  
 Estimated 70dB range: 2,800'  
 Estimated 60dB range: 5,600'

Note: 100' performance levels listed represent repeatable results within +1/-1dB to stated levels.  
 Estimated 70dB perimeter is based on the Federal Emergency Management Agency's (FEMA) -10dB per distance doubled path model.

# WHELEN®

ENGINEERING COMPANY, INC.

PUBLIC WARNING PRODUCTS

Route 145, Winthrop Road  
 Chester, Connecticut 06412-0684

(860) 526-9504

1-800-637-4736

Fax: (860) 526-4784

Internet: [www.whelen.com](http://www.whelen.com)

e-mail: [lowsales@whelen.com](mailto:lowsales@whelen.com)

Whelen Engineering Company, Inc. reserves the right to upgrade its products with design improvements without notification.  
 © 2006 Whelen Engineering Company, Inc.  
 Printed in the U.S.A.  
 120406-11697C

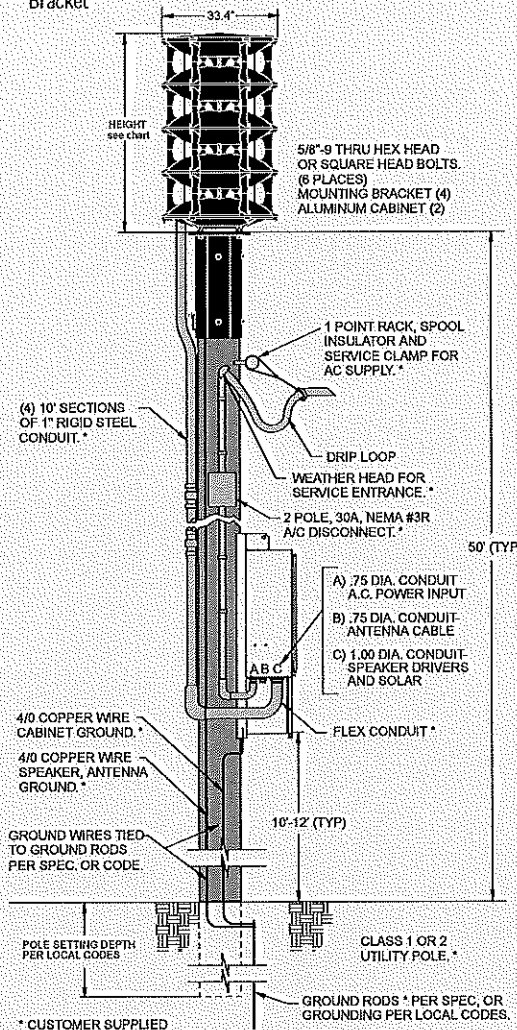
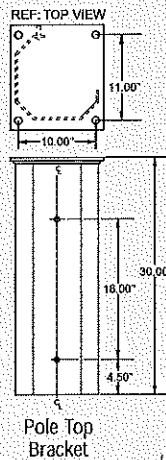

**deputyclerk@cumming.iowa.gov**

---

**From:** Lauren Hoover <lauren.hoover@everbridge.com>  
**Sent:** Thursday, June 25, 2020 2:55 PM  
**To:** deputyclerk@cumming.iowa.gov  
**Subject:** Nixle info inside - pls confirm receipt  
**Attachments:** Nixle Brochure.pdf; Nixle Engage IS 2020.pdf

Angie,

Below is pricing and attached is the respective Nixle Engage data sheet. I have also attached our brochure. I look forward to hearing from you!

**Nixle Engage:** \$2,600 annually with a one-time implementation fee of \$300

Warmly,

Lauren Hoover  
818.275.5439 (PST)  
[lauren.hoover@everbridge.com](mailto:lauren.hoover@everbridge.com)



The content of this email is confidential and intended for the recipient specified in message only. It is strictly forbidden to share any part of this message with any third party, without a written consent of the sender. If you received this message in error, please reply to this message and follow with its deletion, so that we can ensure such an error does not occur in the future.





One Software Platform for  
Community Engagement + Emergency Management Together



ACTIVE SHOOTER



MISSING PERSON



HAZMAT



COMMUNITY EVENTS



SEVERE WEATHER



BOIL WATER



TRAFFIC INCIDENT

SEND



TEXT



EMAIL



VOICE



MOBILE APP



IPAWS



EVERBRIDGE NETWORK



WEBPAGE



FACEBOOK



TWITTER



GOOGLE ALERTS

*“ To engage the public wherever they are when it matters most - that’s what Nixle does for us. ”*

CHARLIE BECK  
LOS ANGELES POLICE CHIEF

Everbridge Nixle has **600** employees dedicated to  
**HELP YOU INFORM AND PROTECT YOUR RESIDENTS**



VISIT [WWW.NIXLE.COM](http://WWW.NIXLE.COM)  
CALL +1-877-649-5362

# GOOGLE+NIXLE+YOU

Nixle is the **first and only** commercial public safety service to partner with Google, **increasing your reach by millions**

- + Unlimited text, email & Web Messaging
- + Unlimited voice minutes
- + Facebook, Twitter & YouTube posting
- + IPAWS Publication
- + Integrated Tipping Platform
- + National Weather Service (NWS) alerts
- + Agency Smart Phone App
- + FOIA Reporting
- + Website Integration
- + Easy text message opt-in
- + Keywords for targeted Messaging
- + GIS targeting of households and neighborhoods

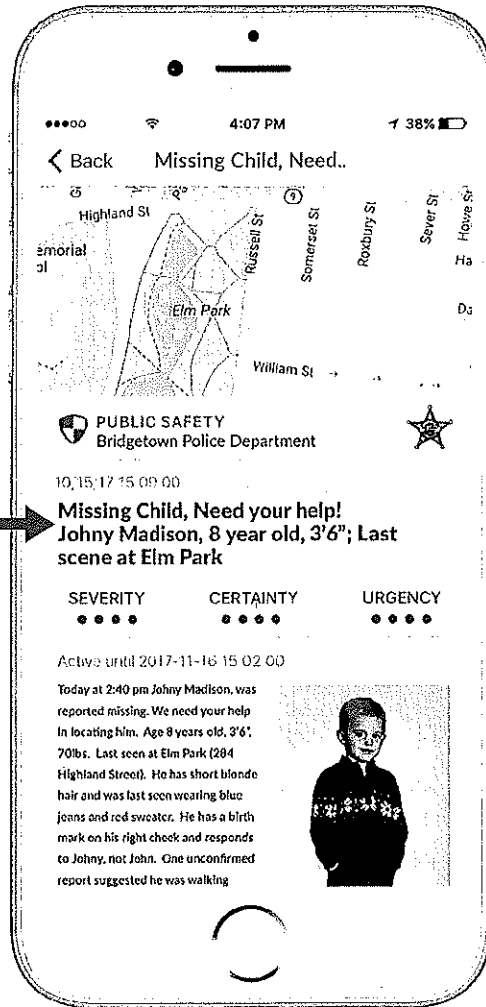
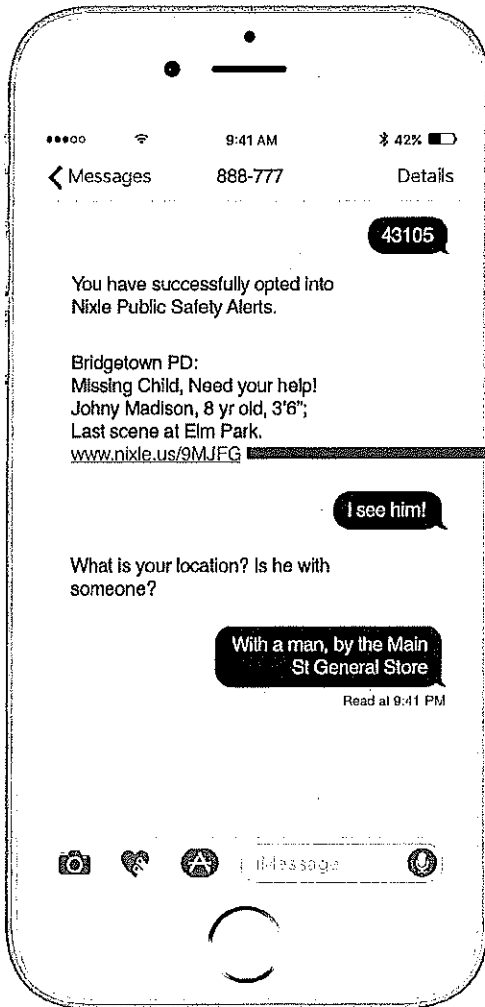

## EVERBRIDGE NIXLE - ENGAGE

Everbridge Nixle Engage is a complete communication solution delivering maximum community impact. Agencies can engage their communities through all channels for ultimate engagement. This solution is only available in specific countries.

**Usage**

- Unlimited email messages
- Unlimited Web messages
- Unlimited Facebook & Twitter notifications
- SMS, Voice notifications are subject to the Everbridge Credit Based Usage Policy. For details, please refer to the **Messaging Credits System Inclusion**.

**Core Platform Access**

- One (1) account
- Unlimited administrators to initiate messages, manage groups and manage users
- Unlimited users with either private or public group permissions
- Unlimited administrator and user access to smart phone publishing application, Engage Bridge
- Ability to access multiple accounts (alternative to Group Level Permissions)
- Includes 5 keywords.

**Key Features**Message types:

- Alerts Messages
- Advisories Messages
- Community Messages
- National Weather Service (NWS) automatic rebroadcast via email and SMS

Publishing Groups

- Access to Nixle Wire Group
- Unlimited Public Group Creation
- Unlimited Private Group Creation
- Unlimited usage of CSV Import tool

Location Targeting / Geo Targeting

- Point & Radius
- City/Town Name or Zip Code

Message Formatting

- Multiple email attachments of PDF, DOC and image file formats (10 MB maximum)
- Scheduled Messaging
- HTML email editor
- Messaging and Email templates
- Spanish translation

Standard Publishing Channels

- Email
- SMS (with hyper link to Message Widget and Agency RSS feed)

*System Inclusion Sheet may be updated by Everbridge with at least thirty (30) days' prior written notice to Client via the Everbridge Client Portal. For a full product description, along with best practices and product details please see the Everbridge User Guide and Everbridge University.*

Des Moines Register  
Published online July 2, 2020

<https://www.desmoinesregister.com/story/news/local/west-des-moines/2020/07/02/google-fiber-partner-west-des-moines-fiber-optic-internet-broadband-iowa-high-speed/3279256001/>

West Des Moines plans to invest nearly \$40 million in a partnership with Google Fiber to bring to the city the ultra-fast network that is available in only 18 other U.S. cities, officials announced Thursday.

An agreement the West Des Moines City Council is expected to approve Monday names Google Fiber as the city's first licensee for the network. Other providers are expected to be licensed later, creating what city officials envision as universal high-speed internet access with competitive prices.

After launching in the Kansas City metro in 2012, Google Fiber has expanded to tech hubs including Austin, Texas; Atlanta; Portland, Oregon; and Seattle. Now, it's coming to West Des Moines, which has attracted other tech giants, including Microsoft, in recent years.

The project marks Google Fiber's Iowa debut. The provider's speeds of one gigabit per second are about 100 times faster than the average broadband connection in the U.S., and fiber optic internet rarely experiences outages that can be common with cable connections.

The city plans to solicit bids for laying the underground conduit that would house the fiber optic cables, and begin installations in public rights-of-way later this year, Deputy City Manager Jamie Letzring told the Des Moines Register.

She pointed to three basic objectives of the collaboration: "We would want to make sure there was a lot of consideration given for digital equity — it needed to go to every single home. ... We would need an approach that would create sort of an open system that would allow for as much competition as possible. ... And finally, a system that would be financially sustainable that had some financial backing to it."

On a monthly basis, Google Fiber would pay the city \$2.25 for each household that connects to the network. The company would install connective equipment at those addresses, said project consultant David Lyons, who formerly led the Iowa Insurance Division and Iowa Department of Economic Development.

Over the 20-year agreement, Google Fiber would pay a minimum of \$4.5 million to the city, he said. Other licensed providers could pay a fee to install their fiber in the city's conduit once the system is completed.

Households would be able to purchase fiber optic internet from Google Fiber or any other provider that offers it, and some households may choose to take advantage of the free connection for future use but remain with their current internet service, Lyons explained.

Cities across Iowa are increasingly focused on providing ubiquitous broadband to residents, with some municipalities, like Cedar Falls, owning their networks and treating the internet as a utility. The public-private partnership in West Des Moines is an uncommon model but allows each party to play to their own strengths — with cities handling infrastructure and technology companies providing services, Lyons said.

"We believe that municipal collaborations, like the one proposed in West Des Moines, and our current project in Huntsville, Alabama, provide incredible opportunities to deliver super fast gigabit internet to many more people," a Google Fiber spokesperson said in an email to the Register.

The city expects to pay somewhere between \$35 million and \$42 million to install the conduit, which consists mostly of PVC piping, according to Lyons. The final cost will depend on how much of the existing fiber-optic infrastructure can be incorporated, he said.

The city expects to issue taxable general obligation bonds to pay for the project, Letzring said. The work would be split into seven parts, with the final section of installations expected to be finished in 2½ years, she said.

Google Fiber gigabit internet would be provided at \$70 a month, a spokesperson said.

Lyons said the fiber optic system can withstand flooding and storms, although frost can potentially pose issues. Once a portion is installed, Google Fiber workers test the connection's reliability before the project is complete, he said.

West Des Moines detailed its goal of having equal access to quality broadband in its 2036 strategic plan. This partnership with Google Fiber, Letzring said, fast-tracks the timeline to make that possible.

In a news release, Mayor Steven Gaer praised the effort, calling high-speed internet access "critical."

"It's amazing that in just four years, West Des Moines is well on its way to achieving the WDM 2036 Plan goal of finding an innovative way to provide access to broadband for all our residents and businesses," the mayor said.

State and local government leaders who spoke at a virtual announcement of the project Thursday noted how vital a reliable internet connection has been during the coronavirus pandemic.

Gaer read a statement from Gov. Kim Reynolds, who applauded the city's "forward-looking leadership" and said that equal access to broadband is more important than ever.

"If we ever needed a reason to focus on connectivity and internet access, COVID-19 gave it to us," said Reynolds' statement. "Like Iowans do, we turn obstacles into opportunities."

West Des Moines Community School District Superintendent Lisa Remy said the initiative would "open doors" for students who would spend more time learning at home as education officials seek safe reopening strategies.

"It will help us as we continue to expand online learning opportunities for all our students," she said.

To sign up for updates on the project, go to [google.com/fiber/wdm](https://google.com/fiber/wdm).

*Shelby Fleig covers Des Moines' western suburbs for the Register. Reach her at [shelbyfleig@dmreg.com](mailto:shelbyfleig@dmreg.com) or 515-214-8933.*

## Angie Ritchie

---

**From:** SFA Billing Tickets DoNotReply <SFA.Billing.Tickets.DoNotReply@CenturyLink.com>  
**Sent:** Monday, March 9, 2020 11:08 AM  
**To:** 'deputyclerk@cumming-iowa.com'  
**Subject:** Century Link Business Bundle

Internet Speed 80M Downstream / 10M Upstream  
Price for line with DSL is \$169.99(monthly) \$159.99 (2 yr term)  
Additional line price \$34.99  
Modem lease \$9.99 monthly or purchase modem \$99.99 plus tax  
Tech install \$59.99

Package price doesn't include tax, fees or surcharges

This communication is the property of CenturyLink and may contain confidential or privileged information. Unauthorized use of this communication is strictly prohibited and may be unlawful. If you have received this communication in error, please immediately notify the sender by reply e-mail and destroy all copies of the communication and any attachments.

July 16, 2020



City of Cumming  
649 N 44<sup>th</sup> St.  
Cumming, IA 50061

### MOSQUITO ABATEMENT SERVICE AGREEMENT

Thank you for the opportunity for ABC Pest Control to provide you with a quote for your mosquito abatement program.

#### SERVICE FREQUENCY

ABC Pest Control, Inc. will provide licensed technicians to service your location on a routine basis governed by mosquito count. Each service shall be done upon client's request.

#### SERVICE SPECIFICATIONS

ABC Pest Control, Inc. will supply all the chemicals and materials necessary for mosquito reduction. Larvicide will be placed in all areas with standing water. Aerosols will be dispensed with a ULV fogger system.

#### NATURE OF WORK, MATERIALS, AND METHODS OF APPLICATION

1. All work will be performed by a state certified applicator, or one who will work under the direct supervision of a certified applicator.
2. We will utilize the most technologically advanced chemicals and methods of application available. Pesticides used will be only those registered by EPA and other regulatory agencies governing our industry. Label recommendations will be strictly followed.

#### SCOPE OF SERVICE

1. Insect Reduction- Mosquitoes.
2. Reduction methods will include:
  - a. Application of larvicide to standing water, specifically to water ditch flowing beside bike path.
  - b. Application of aerosols as needed to reduce the number of adult mosquitoes.

GUARANTEE

ABC Pest Control, Inc. warrants furnishing products and services with specific quality standards designed to meet the needs of existing and potential customers. ABC Pest Control, Inc. shall provide its service and meet its obligations under this Contract in a timely and professional manner. ABC Pest Control, Inc. guarantees to reduce, but will not be held responsible for any health problems associated with mosquito transmitted diseases.

TERMS OF AGREEMENT

This agreement shall be in effect for the summer months only during the mosquito season unless either party gives written thirty (30) day notice of cancelation.

This agreement may not be copied or reproduced without the written consent of ABC Pest Control, Inc.

PRICE STRUCTURE

- 1. Application of Larvicide (Bike Path- 300 briquettes)      \$975.00 per application.
- 2. ULV Fog Aerosol (City streets)                                      \$500.00 per application.

\_\_\_\_\_  
ABC Pest Control, Inc.

\_\_\_\_\_  
Date

\_\_\_\_\_  
City of Cumming

\_\_\_\_\_  
Date



Moret Services LLC  
 2120 Abbott Trl.  
 Cummings, IA 50061  
 (515) 208-4772

084808

<b>ORDER INFO</b>	customer's order no.	phone	date
	name <i>City of Cumming</i>		
	address <i>City Park</i>		
	city, state, zip		
sold by		cash <input type="checkbox"/> charge <input type="checkbox"/> check <input type="checkbox"/> c.o.d. <input type="checkbox"/> on acct. <input type="checkbox"/> # _____	shipping information

quantity	description	price	amount
1	<i>Fill in &amp; Reseed Disturbed</i>		
2	<i>Areas around Water Tower</i>		<i>850.</i>
3			
4	<i>Fill in Rutted Areas in Mulch</i>		
5	<i>Clean up and Reseed</i>	<i>Labors</i>	<i>1450.</i>
6	<i>Perimeter of Mulch Areas</i>		
7			
8	<i>Install New Playground Mulch</i>		
9	<i>over existing Mulch</i>	<i>Labors</i>	<i>1200.</i>
10		<i>Delivng + Mulch</i>	<i>1600.</i>
11	<i>Green all Mulch</i>		<i>300.</i>
12			
13			<i>5400.</i>
14			
15			
16			

received by \_\_\_\_\_

## Angie Ritchie

---

**From:** phil@jpettiecord.com  
**Sent:** Tuesday, July 7, 2020 3:47 PM  
**To:** 'Angie Ritchie'  
**Subject:** RE: IPEMA certified Playground Mulch

Angie,

I stopped out to look at your park and to take some measurements this afternoon. It looks like you could use a minimum of 4" over the whole park. I would recommend using 6" over the whole park to get you up to 12" around all of your play equipment. Here is the prices for delivery only and delivered and blown in using our blower truck.

### Delivery Only

4" depth	\$880.00
5" depth	\$1,040.00
6" depth	\$1,280.00

### Delivered and Blown In Place (Includes the cost of the material)

4" depth	\$2,310.00
5" depth	\$2,730.00
6" depth	\$3,360.00

Thank you for this opportunity to provide this quote to you. If you have any questions or need any further information please do not hesitate to contact me.

Sincerely,

Phil Reiman  
Mulch Division Manager  
Office: (515) 263 – 8900  
Cell: (515) 777 - 6230

---

**From:** Angie Ritchie <deputyclerk@cumming-iowa.com>  
**Sent:** Tuesday, July 7, 2020 12:13 PM  
**To:** phil@jpettiecord.com  
**Subject:** RE: IPEMA certified Playground Mulch

Please send a quote for mulch for our small park. We have a larger park in the works but that I do not know when we will be needing mulch for that one.

Please update my email with [deputyclerk@cumming.iowa.gov](mailto:deputyclerk@cumming.iowa.gov)

Thanks!

Angie Ritchie  
Deputy Clerk  
City of Cumming

# Estimate

Quote expires: 5/16/2020

Estimate #: 1R-0115

Ticket date: 3/17/2020

Sales Rep: JL

Page: 1



Ted Lare Design Build Inc.  
PO BOX 67  
2701 Cumming Ave  
Cumming, IA 50061

(515) 981-1073  
www.TedsGardens.com

Quoted To: City of Cumming  
649 N 44th St  
Cumming, IA 50061

Ship to:

Customer #: 10964

## Spring Maintenance & Mulching

Item #	Quantity	Selling unit	Description	Price	Ext prc
<b>East and South of City Hall</b>					
4326	36	BAG	Mulch Hardwood	5.50	198.00T
4768	1.00	HOPPER	Snapshot Weed Preventer	14.00	14.00T
5498	0.50	EACH	Haul Away & Disposal	150.00	75.00T
3286	4.00	EACH	Labor Spring Maintenance Labor to Edge Beds, Cut Back Perennials, Trim Shrubs, Apply Snapshot and Re-Mulch 1 1/2" Thick	75.00	300.00T
<b>East and South of City Hall Subtotal:</b>					<b>587.00</b>
<b>Arborvitae Hedge</b>					
4326	54	BAG	Mulch Hardwood	5.50	297.00T
4768	1.00	HOPPER	Snapshot Weed Preventer	14.00	14.00T
5498	0.50	EACH	Haul Away & Disposal	150.00	75.00T
3286	4.00	EACH	Labor Spring Maintenance Labor to Edge Beds, Apply Snapshot and Re-Mulch 1 1/2" Thick	75.00	300.00T
<b>Arborvitae Hedge Subtotal:</b>					<b>686.00</b>
<b>Lilacs</b>					
4326	20	BAG	Mulch Hardwood	5.50	110.00T
4768	1.00	HOPPER	Snapshot Weed Preventer	14.00	14.00T
ROUND	2.00	Mixed Gallons	Round-Up Powder Quick Pro	8.75	17.50T
5498	0.50	EACH	Haul Away & Disposal	150.00	75.00T
3286	3.00	EACH	Labor Spring Maintenance Labor to Edge Beds, Trim Shrubs, Apply Snapshot and Re-Mulch 3" Thick, Spraying and Removing Weeds Included	75.00	225.00T
<b>Lilacs Subtotal:</b>					<b>441.50</b>
<b>By Restroom</b>					
4326	69	BAG	Mulch Hardwood	5.50	379.50T
4768	1.00	HOPPER	Snapshot Weed Preventer	14.00	14.00T
5498	1.00	EACH	Haul Away & Disposal	150.00	150.00T
3286	5.00	EACH	Labor Spring Maintenance Labor Cut Back Perennials, Apply Snapshot and Re-Mulch 3" Thick	75.00	375.00T
<b>By Restroom Subtotal:</b>					<b>918.50</b>
<b>Play Equipment Area</b>					
ROUND	5.00	Mixed Gallons	Round-Up Powder Quick Pro	8.75	43.75T
SO	220.00	EACH	Bags Brown Pine Nuggets	8.56	1,883.20T
4768	4.00	HOPPER	Snapshot Weed Preventer	14.00	56.00T
5500	14.00	EACH	Labor to Spray, Edge & Spread Nuggets	75.00	1,050.00T
5498	2.00	EACH	Haul Away & Disposal	150.00	300.00T
<b>Play Equipment Area Subtotal:</b>					<b>3,332.95</b>

# Estimate



Ted Lare Design Build Inc.  
PO BOX 67  
2701 Cumming Ave  
Cumming, IA 50061

(515) 981-1073  
www.TedsGardens.com

Quote expires: 5/16/2020  
Estimate #: 1R-0115

Ticket date: 3/17/2020

Sales Rep: JL

Page: 2

Quoted To: City of Cumming  
649 N 44th St  
Cumming, IA 50061

Ship to:

Customer #: 10964

## Spring Maintenance & Mulching

Item #	Quantity	Selling unit	Description	Price	Ext prc
<b>Plant Tree in Blue Spruce Location</b>					
28801	1	EACH	Crabapple Zumi #7	149.99	149.99T
4326	12	BAG	Mulch Hardwood	5.50	66.00T
5512	1	EACH	Labor to Plant and Mulch	162.00	162.00T
				<b>Plant Tree in Blue Spruce Location Subtotal:</b>	<b>377.99</b>
5499	1	EACH	Fuel Charge	126.88	126.88

Sale subtotal: 6,470.82

Tax: 444.08

**Total: 6,914.90**

Ted Lare Design Build is not responsible for the locate, repair, or cost of repair for private utilities. These would include but are not limited to irrigation, lighting, speaker wires, invisible fence, private gas, water, or electric, etc. Unless otherwise stated, incidental damage to the property such as utilities, sod, irrigation & concrete repairs are an added cost.

GUARANTEE: Trees and shrubs installed by Ted Lare Design Build, Inc have a onetime replacement guarantee effective for one year after installation, labor for replacemnt is included. Ornamental grasses, roses and perennials have a 90 day guarantee.